

THYRA

# CT10M SERIES USER MANUAL

VECTOR CONTROL/VF CONTROL OPEN LOOP CONTROL



## Preface

Thank you for using our CT10M series products!

Information code.

Release date.

Version number: Ver A02

CT10M series is our high reliability, small size and high cost performance product, which supports high performance drive of three-phase asynchronous motor, supports international leading vector control technology and common V/F control mode, supports speed and torque control output mode.

This instruction manual describes how to properly use the CT10M series. Please be sure to read this instruction manual carefully before using (installation, operation, maintenance, inspection, etc.). Also, please understand the safety precautions before using the product.

Special emphasis: In order to ensure the performance of the product, please confirm the setting of the motor nameplate parameters: rated voltage, rated current, rated power, rated frequency, rated speed, and the number of poles and other motor parameters when using the product for the first time.

### Cautions

- When using this product, be sure to install the case or cover as specified and follow the instructions.
- The illustrations in this instruction manual are for illustration purposes only and may differ from the product you ordered.
- The contents of this manual are subject to change in a timely manner due to product upgrades or specification changes, as well as to improve the convenience and accuracy of the manual.
- If you need to order an instruction manual due to damage or loss, please contact our regional agents or contact our customer service center directly.
- If you still have some usage problems that are unknown, please contact our customer service center.

# Table of Contents

<b>Foreword</b> .....	1
<b>Catalog</b> .....	2
<b>Chapter 1 Safety Information and Precautions</b>	
1.1 Safety matters .....	3
1.2 Caution .....	5
1.3 First-time use of .....	7
<b>Chapter 2 Product Information</b>	
2.1 Naming rules .....	08
2.2 Product nameplate .....	09
2.3 Product Line .....	09
2.4 Technical specifications .....	11
2.5 Product shape and installation dimension drawing .....	13
2.6 Braking Resistor Selection Guide .....	18
2.7 Product Selection Guide .....	18
<b>Chapter 3 Installation and Wiring</b>	
3.1 Mechanical installation .....	20
3.2 Electrical Installation .....	20
3.3 Control board wiring instructions .....	26
<b>Chapter 4 operation panel and display</b>	
4.1 Introduction to the operation and display interface .....	32
4.2 Function code view modification method description .....	33
4.3 Monitoring status display .....	34
<b>Chapter 5 Basic Operation and Commissioning</b> . .	
5.1 Quick debugging process .....	35
5.2 Introduction to Common Functions .....	36
<b>Chapter 6 Functional parameters table</b>	
6.1 CT10M Function Code Group Overview Table .....	38
6.2 Summary table of CT10M functional parameters .....	38
<b>Chapter 7 Troubleshooting and abnormal treatment</b>	
7.1 Causes of failures and their countermeasures .....	67
7.2 Common Troubleshooting .....	67
<b>Chapter 8 Maintenance and Care</b>	
8.1 Daily inspection items .....	68
8.2 Periodic inspection items .....	68
<b>Appendix A Modbus Communication Protocol</b> .....	72
1. Bus structure	
2. Communication data format	
3. Function code parameter address labeling rules	
<b>Warranty Agreement</b>	
<b>Product Warranty Card</b>	

# Chapter 1 Safety Information and Precautions

## Security Definition.

Description of safety markings that may be covered in this manual.



Danger: Failure to operate as required may result in fire or serious injury, or even death.



Note: Moderate injuries or minor injuries may result and equipment damage may occur due to failure to operate as required.

Please read this chapter carefully and be sure to follow the safety precautions required by the contents of this chapter when installing, commissioning and servicing this product. Any injury or loss caused by irregular operation is not the responsibility of our company.

## 1.1 Safety matters

### 1.1.1 Before installation



#### Danger

- When you find water in the box, please stop the installation!
- Stop the installation if you find visual parts missing or parts damaged!
- If you find that the product nameplate parameters do not correspond to the required product, please stop the installation!



#### Attention

- Please do your best to protect yourself from injury when handling the product!
- Please be careful during handling to avoid damage to the product!
- Before leaving the factory, the product has done qualified pressure resistance test, please do not carry out pressure resistance check again, so as not to damage the product by irregular operation!

### 1.1.2 When installing



#### Danger

- The product should be installed on metal or other flame retardant objects, otherwise there is a fire hazard!
- Do not unscrew the fixing bolts of the equipment components, especially those marked with red!
- The product must not be installed in an environment containing explosive gases, otherwise there is a risk of explosion!

## CT10M Series User Manual



### Attention

- Handle gently, and hold the bottom of the product to prevent foot injury or damage to the product!
- Do not allow wire heads or screws to fall into the product. Otherwise cause damage to the product!
- Please install the product in a place with little vibration and avoid direct sunlight!
- When the product is installed in the cabinet, need to do a good job of heat dissipation, otherwise it may cause product failure or damage!

### 1.1.3 Wiring



### Danger

- Wiring operations must be performed by professionally qualified personnel, otherwise there is a risk of electric shock or equipment damage!
- There must be a circuit breaker separating the product from the power supply, otherwise a fire may occur!
- Please make sure the power supply is in zero energy state before wiring, otherwise there is a risk of electric shock!
- It is forbidden to connect the braking resistor directly between the DC bus (+) and (-) terminals, otherwise it will cause a fire!
- The product must be covered before powering up, otherwise it may cause electric shock!
- The wiring of all peripheral accessories must comply with the instructions in this manual and be wired correctly in accordance with the circuit connection methods provided in this manual, or else cause an accident!



### Attention

- All of our products have been tested for voltage resistance at the factory, so it is forbidden to conduct this test on the products again, otherwise there is a risk of equipment damage!
- The terminal signal line of the product should be wired as far away from the main power line as possible, and the distance cannot be guaranteed in the case of vertical cross distribution, otherwise it will cause interference with the control signal!
- When the motor cable length is greater than 100 meters, it is recommended to use output reactors, otherwise there is a risk of equipment failure!
- The encoder must use a shielded cable and the shield must be properly grounded!

### 1.1.4 Operation



### Danger

- After the wiring is completed and confirmed, it is necessary to ensure that the cover has been covered before power is applied, and it is strictly prohibited to open the cover after power is applied, otherwise there is a risk of electric shock!
- Do not touch the product and the surrounding circuitry after the product is powered on, no matter what state

## CT10M Series User Manual

the product is in, otherwise there is a risk of electric shock!

- During the operation of the product, foreign objects should be avoided to fall into the equipment, otherwise there is a risk of equipment damage!
- At the beginning of power on, the product automatically to the external strong circuit for safety detection, at this time, must not touch the product U, V, W terminals or motor terminals, otherwise there is a risk of electric shock!
- Storage time of more than 2 years of products, the application of voltage regulators to gradually step up the power supply before supplying power from the grid, otherwise there is a risk of equipment damage!
- Non-technical professionals are forbidden to test signals in operation, otherwise there is a risk of injury or equipment damage!



### Attention

- Check if there is a short circuit in the peripheral circuit connected to the product and if the connection is tight, otherwise it may cause damage to the equipment!
- Before running, please make sure the motor and machinery are within the allowed use range, otherwise the equipment may be damaged!
- Do not touch the fan, heat sink, brake resistor directly, otherwise there is a risk of mechanical damage and burns!
- When performing rotation recognition, please ensure the safety of the surrounding area after the equipment is in operation!

## 1.1.5 Maintenance



### Danger

- Product maintenance, inspection or replacement of parts must be performed by a professionally qualified engineer!
- It is forbidden to carry out maintenance, inspection or replacement of parts with electricity, otherwise there is a risk of electric shock!
- Wait for at least 10 minutes after power failure to ensure that the residual voltage of the electrolytic capacitor drops below 36V before performing maintenance, inspection or replacement of parts!
- After replacing the product must be set parameters, all pluggable plug-ins must be plugged in the case of power failure!



### Attention

- Maintenance, inspection or replacement of parts try not to touch the body of the components, otherwise there is a risk of electrostatic damage to the device!
- All pluggable actions must be carried out in the case of power failure!

### 1.2 Notes

#### 1.2.1 Motor insulation inspection

Motor insulation inspection should be done before the first use, reuse after a long time and regular inspection to prevent damage to the product due to insulation failure of the motor winding. Insulation inspection must be separated from the motor connecting line from the product, it is recommended to use 500V voltage megohmmeter, should ensure that the measured insulation resistance is not less than 5MΩ.

#### 1.2.2 Thermal protection of the motor

If the motor selected does not match the rated capacity of the product, especially if the rated power of the product is greater than the rated power of the motor, be sure to adjust the value of the parameters related to motor protection in the product or install a thermal relay in front of the motor to protect the motor.

#### 1.2.3 Operation above industrial frequency

This product can provide output frequency from 0Hz to 500Hz. If the customer needs to operate at 50Hz or above, please consider the mechanical device's capacity.

#### 1.2.4 Vibration of mechanical devices

The product may encounter mechanical resonance points of the load device at some output frequencies, which can be avoided by setting the product jump frequency parameter.

#### 1.2.5 About motor heat and noise

Since the output voltage of the product is PWM wave, it contains certain harmonics, so the temperature rise, noise and vibration of the motor will be slightly increased compared with the working frequency operation.

#### 1.2.6 Output side with voltage sensitive devices or capacitors to improve power factor

The output of the product is PWM wave, the output side, such as the installation of capacitors to improve the power factor or lightning protection with varistors, etc., easy to trigger the product instantaneous over-current or even damage the product, please do not use.

#### 1.2.7 Product inputs and outputs used in contactors and other switching devices

If a contactor is installed between the power supply and the product input, it is not allowed to use this contactor to control the start/stop of the product. Frequent charging and discharging tend to reduce the service life of capacitors in the product. If a switch device such as a contactor is installed between the output and the motor, ensure that the product is operated on and off when there is no output, otherwise it is easy to cause damage to the module inside the product.

#### 1.2.8 Use outside the rated voltage value

Use of the CT10M series outside the allowable operating voltage range specified in the manual is not suitable and may cause damage to the devices in the product. If necessary, please use the appropriate step-up or step-down device to change the voltage.

### 1.2.9 Three-phase input to two-phase input

Do not change the CT10M series of three-phase products to two-phase use. Otherwise, it will lead to malfunction or product damage. If the power grid is two-phase input, please consult the manufacturer's maintenance personnel to make sure that the correct product specification model selection is provided.

### 1.2.10 Lightning surge protection

This series of products are equipped with lightning overcurrent protection device, which has certain self-protection capability for induction lightning. For lightning frequent place customers should also add protection in the front of the product.

### 1.2.11 Altitude and derating use

In areas where the altitude exceeds 1000m, it is necessary to use the product at a reduced rate because the thin air causes the product to lose heat. Please contact our company for technical consultation in this case.

### 1.2.12 Attention at the end of the product

The electrolytic capacitors in the main circuit and the electrolytic capacitors on the printed circuit board may explode when they are burned. Toxic gas is generated when the plastic parts are incinerated. Please dispose of them as industrial waste.

### 1.2.13 About adapted motors

- 1) The standard adaptable motor is a four-pole squirrel cage induction motor or a permanent magnet synchronous motor. If the motor is not one of the above, please make sure to match the product according to the rated current of the motor.
- 2) Non-inverter motor cooling fan and rotor shaft is coaxially connected, the cooling effect of the fan decreases when the speed decreases, therefore, the motor overheating occasions should be installed with a strong exhaust fan or replaced with an inverter motor.
- 3) The product has built-in standard parameters of the adapted motor, according to the actual situation it is necessary to identify the motor parameters or modify the default value to conform to the actual value as far as possible, otherwise it will affect the operation effect and protection performance.
- 4) A short circuit inside the cable or motor can cause the product to alarm or even blow up. Therefore, please first perform an insulation short circuit test on the motor and cable of



the initial installation, and this test should be performed frequently during daily maintenance. Note that this test must be done with the product completely disconnected from the part being tested.

### 1.3 Initial use

For the first time user of this product, you should read this manual carefully first. If you have doubts about some functions and performance, please consult our technical support staff to get help, which is beneficial to the correct use of this product.

Due to the commitment to continuous improvement of our products, the information provided by us is subject to change without notice.

**CT10M series products comply with the following international standards, and some of them have passed CE certification.**

IEC/EN 61800-5-1:2003 Safety requirements for speed-adjustable electrical drive systems.

IEC/EN 61800-3: 2004 Speed-adjustable electrical drive systems; Part III: Standard for electromagnetic compatibility of products and its specific test methods (meeting the requirements of IEC/EN 61800-3 standard under conditions of correct installation and proper use as described in chapter 6.3)

# Chapter 2 Product Information

## 2.1 Naming rules

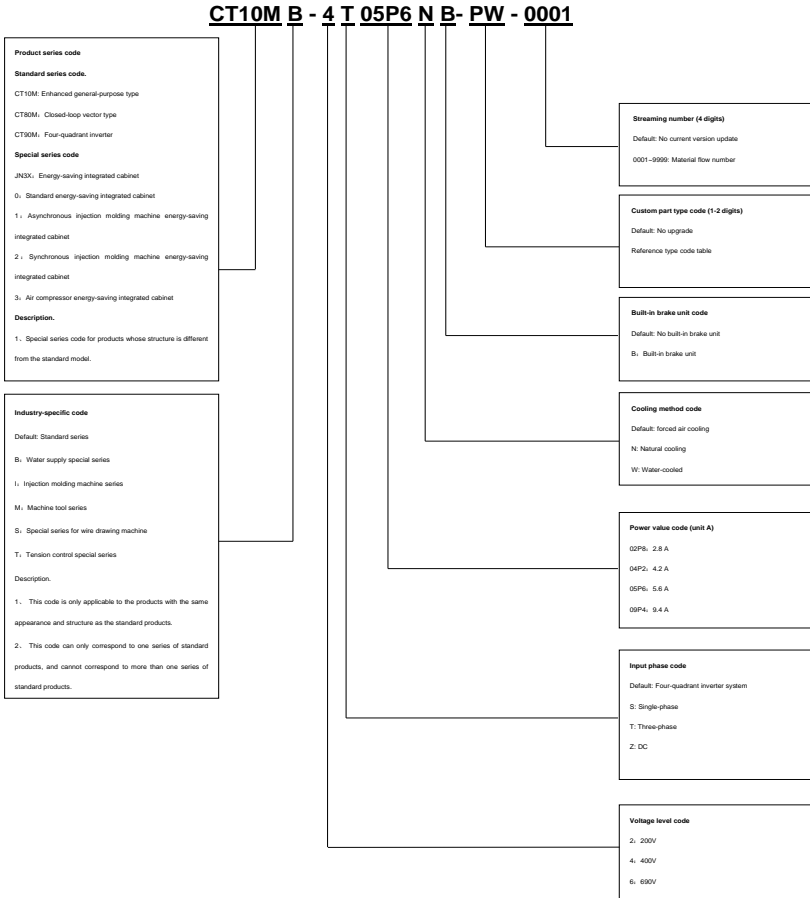

Figure 2-1 CT10M series naming convention

2.2 Nameplate

Model:	CT10M-4T2.2B
Power:	2.2kWG/3.7kWP
Input:	3PH/380V 5.8A 50Hz60Hz
Output:	3PH/380V 5.6A 0Hz-600Hz
S/N:	Barcode
XXXXXXXX XXXX TECHNOLOGY Co.,LTD	

Figure 2-2 CT10M series nameplate identification

2.3 Product Line

Table 2-1 CT10M series product type and technical data

Product Model	Input Current	Output Current	Power supply capacity	Adapted motor	
	A	A	KVA	kW	Brake Unit
<b>220V voltage level series products</b>					
CT10M-2S02P8B	5.4	2.3	1.4	0.4	Built-in optional
CT10M-2S04P8B	8.2	4	2.2	0.75	Built-in optional
CT10M-2S0008B	14.0	7	3.7	1.5	Built-in optional
CT10M-2S0010B	25.0	9.6	5.5	2.2	Built-in optional
CT10M-2S0013B	29.0	13	7.1	3.0	Built-in optional
CT10M-2S0017B	35	17	8.5	4.0	Built-in optional
CT10M-2T0025B	34	25	9	5.5	Built-in
CT10M-2T0032B	43	32	11	7.5	Built-in
CT10M-2T0037B	50	37	14	9	Built-in
CT10M-2T0045B	58	45	17	11	Built-in
CT10M-2T0060B	78	60	21	15	Built-in
CT10M-2T0075B	95	75	24	18.5	Built-in
CT10M-2T0090B	112	90	30	22	Built-in optional
CT10M-2T0110B	142	110	42	30	Built-in optional
<b>380V voltage level series products</b>					
CT10M-4T01P5B*	2	1.5	0.75	0.4	Built-in optional
CT10M-4T02P5B*	2.8	2.1	1.5	0.75	Built-in optional
CT10M-4T04P2B*	5	3.8	3	1.5	Built-in optional
CT10M-4T05P6B*	6.7	5.1	4	2.2	Built-in optional

## CT10M Series User Manual

Product Model	Input Current	Output Current	Power supply capacity	Adapted motor	
	A	A	KVA	kW	Brake Unit
CT10M-4T09P4B*	12	9.0	6	3.7	Built-in optional
CT10M-4T0013B*	17.5	13	9	5.5	Built-in optional
CT10M-4T0017B	22.8	17	11	7.5	Built-in
CT10M-4T0025B	33.4	25	17	11.0	Built-in
CT10M-4T0032B	42.8	32	21	15.0	Built-in
CT10M-4T0037B	49.5	37	24	18.5	Built-in
CT10M-4T0045B	59	45	30	22	Built-in
CT10M-4T0060B	78.3	60	43	30	Built-in
CT10M-4T0075B	97	75	63	37	Built-in
CT10M-4T0090B*	117	91	81	45	Built-in optional
CT10M-4T0110B*	144.5	112	97	55	Built-in optional
CT10M-4T0152	157	150	127	75	
CT10M-4T0176	180	176	150	90	
CT10M-4T0210	221	210	179	110	
CT10M-4T0253	261	253	220	132	
CT10M-4T0304	320	304	263	160	
CT10M-4T0350	374	350	306	185	
CT10M-4T0380	383	380	334	200	
CT10M-4T0426	431	426	375	220	
CT10M-4T0465	480	465	404	250	
CT10M-4T0520	535	520	453	280	
CT10M-4T0590	575	590	517	315	
CT10M-4T0650	627	650	565	355	
CT10M-4T0725	697	725	629	400	

## 2.4 Technology Specifications

Input and output characteristics	Rated input voltage	200V voltage level: single/three-phase 220VAC
		400V voltage level: three-phase 380VAC voltage, continuous fluctuation $\pm 10\%$ , brief fluctuation $-15\%$ to $+10\%$
	Rated input frequency	50Hz/60Hz $\pm 5\%$
	Output Voltage	3 phases: 0 to rated input voltage, error less than $\pm 3\%$

	Output Frequency	0.00~600.00Hz, unit 0.01Hz
	Overload capacity	150% 1 minute; 180% 10 seconds; 200% 0.5 seconds
Operation control characteristics	Control method	V/f control PG-free vector control (SVC)
	Speed range	1:100 (V/f) 1:200 (SVC)
	Speed control accuracy	±0.5% (V/f control) ±0.2% (SVC)
	Speed fluctuations	±0.3% (SVC)
	Torque Response	<10ms (SVC)
	Starting torque	0.5Hz: 180% (V/f, SVC) 0.25Hz: 180% (SVC)
	Basic Functions	V/F curve
V/F separation		2 ways: full separation, semi-separation
Acceleration and deceleration curves		Straight line or S curve acceleration and deceleration mode; four acceleration and deceleration times; acceleration and deceleration time range 0.0~60000s
DC brake		DC braking frequency: 0.00Hz~maximum frequency, braking time: 0.0s~30.0s, braking action current value: 0.0%~100.0%
Pointing control		Pointing frequency range: 0.00Hz~50.00Hz; pointing acceleration and deceleration time 0.0s~60000s
Simple PLC, multi-segment operation		Up to 16-speed operation via built-in PLC or control terminal
Built-in PID		Easy to implement closed-loop control system for process control
Automatic Voltage Regulation (AVR)		When the grid voltage changes, it can automatically maintain the output voltage constant Automatic limitation of current and voltage during operation to prevent frequent over-current and over-voltage tripping

	<p>Over-pressure and over-drain speed control</p> <p>Fast current limiting function</p>	<p>Minimize overcurrent faults and protect products from normal operation</p>
	<p>Torque limiting and control</p>	<p>Automatic torque limitation during operation to prevent frequent overcurrent tripping</p>
	<p>Input terminals</p>	<p>Six switching input terminals, including X6 for high-speed pulse input. Support active open collector NPN, PNP and dry contact input mode, two analog input terminals, one for voltage and current input optional, one for voltage input</p>
	<p>Output terminals</p>	<p>A high-speed pulse output terminal, 0 ~ 50kHz square wave signal output, can realize the set frequency, output frequency and other physical quantity output, a switch output terminal, a set of relay output terminal</p> <p>One analog output terminal, voltage and current output can be selected to realize the output of physical quantities such as set frequency and output frequency</p>
<p>Featured Features</p>	<p>Various main and auxiliary feed and switch, speed search, multiple acceleration and deceleration curves selection, holding brake control, up to 16-segment speed operation (two-segment speed support flexible frequency feed), swing frequency control operation, fixed length control, counting function, over-excitation braking, over-voltage stall, under-voltage stall, power failure restart, jump frequency, frequency binding, four-segment acceleration and deceleration time free switching, motor temperature protection, flexible fan control, process PID control, simple PLC, sag control, parameter recognition, weak magnetic control, high precision torque limiting, V/f separation control</p>	
<p>Protection function</p>	<p>Power-on motor short-circuit detection, over-current protection, overvoltage protection, undervoltage protection, overheat protection, overload protection, etc.</p>	

Environment	Place of use	Indoor, not exposed to direct sunlight, no dust, corrosive gases, flammable gases, oil mist, water vapor, dripping water or salt, etc.
	Altitude	The rated output current will be derated by 1% for every 100 meters of elevation above 1000 meters.
	Ambient temperature	-10℃~40℃, 40℃~50℃ between the derating use, rise 1℃, the rated output current is reduced by 1%
	Humidity	5~95%, no condensation allowed
	Vibration	Less than 5.9 m/s <sup>2</sup> (0.6g)
	Storage temperature	-20℃~+60℃
Other	Installation method	Wall-mounted
	Protection level	IP20
	Cooling method	Forced air cooling

2.5 Product appearance drawing, installation hole size

2.5.1 Product appearance

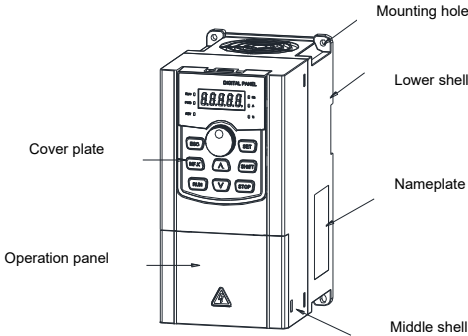

Figure 2-3 CT10M series plastic case appearance diagram

2.5.2 Mounting hole dimensions Figure

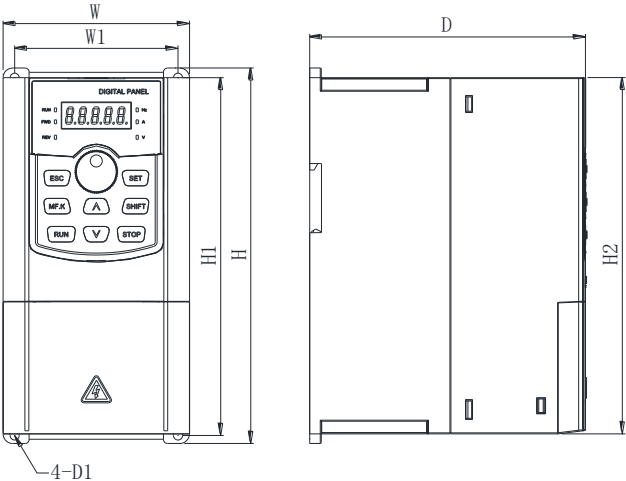

Figure 2-4 Plastic shell mounting hole size diagram

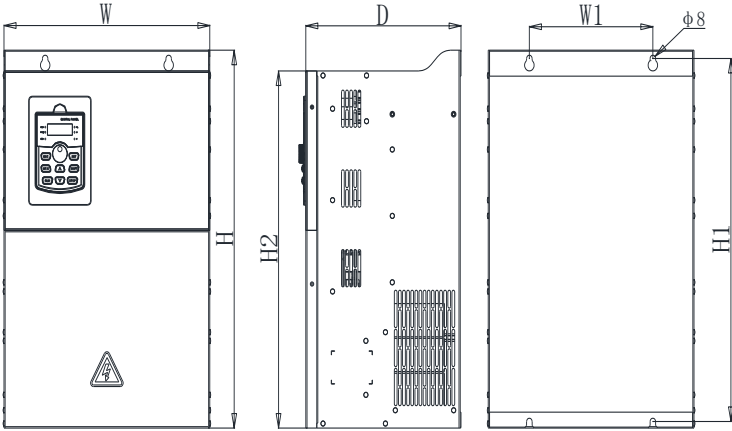

Figure 2-5 CT10M Series Sheet Metal Housing Mounting Hole Dimension Diagram



Table 2-2 CT10M series plastic shell products appearance and installation hole size (mm)

Model	Outer Dimension (mm)						Fixing hole	Weight (kg)
	W1	H1	H	H2	W	D		
CT10M-2S/T04P8B	67.5	160	170	/	84.5	129	ø4.5	1.0
CT10M-2S/T0008B								
CT10M-4T04P2B								
CT10M-4T05P6B								
CT10M-2S/T0010B	85	185	194	/	97	143.5	ø5.5	1.4
CT10M-2S/T0013B								
CT10M-4T09P4B								
CT10M-4T0013B								
CT10M-2T0017B	106	233	245	/	124	171.2	ø5.5	2.5
CT10M-2T0025B								
CT10M-4T0017B								
CT10M-4T0025B								
CT10M-2T0032B	147	298	310	/	165	186	ø6	5.1
CT10M-2T0045B								
CT10M-4T0032B								
CT10M-4T0037B								
CT10M-4T0045B								

Table 2-3 CT10M product sheet metal case mounting hole dimensions (mm)

Product Model	Mounting hole position mm		Body external dimensions mm				Mounting hole diameter mm	Weight kg
	W1	H1	H	H2	W	D		
CT10M-4T0037B	120	317	335	/	200	178.2	ø8	8.4
CT10M-4T0045B								
CT10M-4T0060B	150	372	390	/	255	195	ø8	14.8
CT10M-4T0075B								
CT10M-4T0090B	180	437	455		300	225	ø 10	35
CT10M-4T0112B								

CT10M-4T0150	260	510	530		310	258	ø 12	43
CT10M-4T0176								
CT10M-4T0210	260	750	785		395	285	ø 12	50
CT10M-4T0253	280	762	790		500	350	ø 13	85
CT10M-4T0310								
CT10M-4T0350								
CT10M-4T0380	280	1130	1160		500	385	ø 13	120
CT10M-4T0430								
CT10M-4T0470								
CT10M-4T0520								
CT10M-4T0590	280	1220	1250		500	360	ø 16	165
CT10M-4T0650								
CT10M-4T0725								

2.5.3 External keypad 1 dimensions

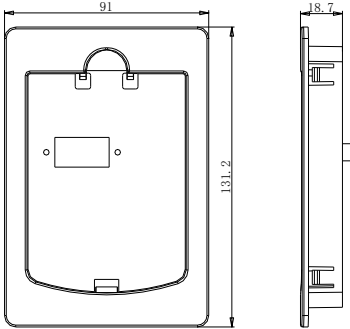

Figure 2-5 External keyboard 1 mounting base external dimensions

2.5.4 External lead keypad 1 installation opening size.

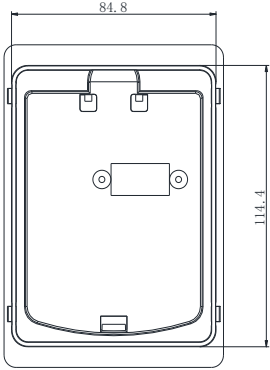

Figure 2-6 External lead keyboard 1 mounting base opening dimensions

2.5.5 External keypad 2 form factor

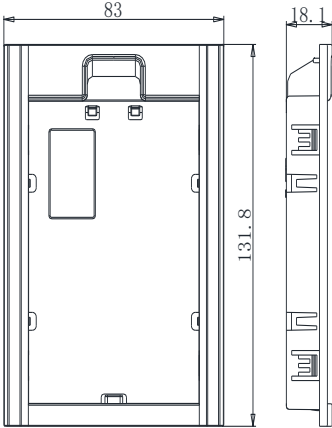

Figure 2-7 External keyboard 2 external dimensions

2.5.6 Dimensions of the mounting openings for the external lead keypad 2.

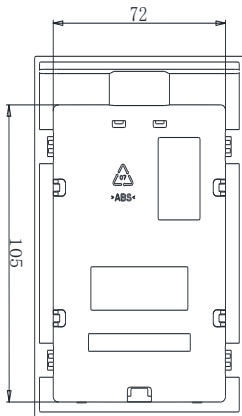

Figure 2-8 Dimensions of the mounting opening of the external lead keyboard 2

2.6 Brake component selection guide

Table 2-3 CT10M series brake components selection table

Product Model	Recommended power of braking resistor	Recommended resistance value of braking resistor	Brake Unit	Remarks
CT10M-2S/T02P8B	80W	$\geq 100\Omega$	Built-in optional or standard built-in	After the model number Add "B"
CT10M-2S/T04P8B	150W	$\geq 100\Omega$		
CT10M-2S/T0008B	200W	$\geq 80\Omega$		
CT10M-2S/T0010B	300W	$\geq 50\Omega$		
CT10M-2S/T0013B	400W	$\geq 40\Omega$		
CT10M-2T0017B	450W	$\geq 30\Omega$		
CT10M-2T0025B	600W	$\geq 20\Omega$		
CT10M-2T0032B	800W	$\geq 15\Omega$		
CT10M-2T0037B	1000W	$\geq 10\Omega$		
CT10M-2T0045B	1000W	$\geq 10\Omega$		
CT10M-4T02P5B	150W	$\geq 250\Omega$		

CT10M-4T04P2B	150W	$\geq 100\Omega$		
CT10M-4T05P6B	300W	$\geq 100\Omega$		
CT10M-4T09P4B	450W	$\geq 100\Omega$		
CT10M-4T0013B	500W	$\geq 80\Omega$		
CT10M-4T0017B	500W	$\geq 75\Omega$		
CT10M-4T0025B	800W	$\geq 30\Omega$		
CT10M-4T0032B	1000W	$\geq 25\Omega$		
CT10M-4T0037B	1300W	$\geq 16\Omega$		
CT10M-4T0045B	1500W	$\geq 16\Omega$		
CT10M-4T0060B	2000W	$\geq 16\Omega$		
CT10M-4T0075B	2000W	$\geq 16\Omega$		
CT10M-4T0090B*	3000W	$\geq 10\Omega$		
CT10M-4T0110B*	3600W	$\geq 5\Omega$		

Note: The braking resistor resistance value selection, please strictly follow the above table selection, otherwise it may lead to damage to the built-in brake unit or resistor damage.

## 2.7 Selection guidance

This product can provide two types of control: normal V/F, SVC.

When selecting products, we must first clarify the technical requirements of the system for variable speed control, the application of the product and the specific characteristics of the load, and from the adaptable motor, output voltage, rated output current and other factors for comprehensive consideration, and then select the model to meet the requirements and determine the mode of operation.

Generally speaking: the rated load current of the motor cannot exceed the rated current of the inverter product. It is necessary to select the mating motor capacity or output current capability as specified in the manual, paying attention to comparing the rated current of the motor and the product. The overload capacity of the product is only meaningful for the starting and braking process. Where there is a short time overload during operation, it will cause a change in load speed. If speed accuracy is required, please consider enlarging one power stage.

Fan and pump types: lower requirements in terms of overload capacity, because the load torque is proportional to the square of the speed, so the load is lighter at low speed operation (except Roots fan) and because there is no special requirement for speed accuracy for this type of load, so choose the square torque V/F.

Constant torque loads: Most loads have constant torque characteristics, but the requirements in terms of speed accuracy and dynamic performance are generally not high. For example, extruders, mixers, conveyors, in-plant transportation trams, translation mechanism of cranes, etc. Multi-stage V/F operation mode can be selected during selection.

The controlled object has certain dynamic and static index requirements: such loads generally require hard mechanical characteristics at low speed to meet the dynamic and static index requirements of the production process to the control system. The SVC control mode can be selected during the selection.

The object to be controlled has high dynamic and static index requirements: for speed regulation accuracy and dynamic performance indicators have high requirements and high-precision synchronous control occasions, the company's other series of high-end products can be used. For example, elevator, paper, plastic film processing line.

## Chapter 3 mechanical and electrical installation

### 3.1 Mechanical installation

#### 3.1.1 Installation Environment and requirements.

- 1) Ambient temperature: The operating ambient temperature of the product is not allowed to exceed the allowable temperature range (-10℃~50℃).
- 2) Mount the product on the surface of a flame retardant object with enough space around it to dissipate heat. The product tends to generate a lot of heat when working. And install it vertically on the mounting support with screws.
- 3) Please install in a place where vibration is not easy. The vibration should be no more than 0.6G. Special attention should be paid to keep it away from equipment such as punching machines.
- 4) Avoid installation in direct sunlight, humidity, and water droplets.
- 5) Avoid installation in places where there are corrosive, flammable and explosive gases in the air as well as oil, dust and metal powder.

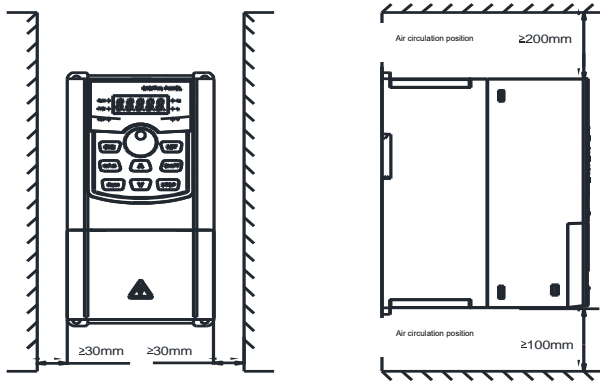

Figure 3-1 Installation diagram of CT10M series inverter

**For top and bottom installation:** When the product is installed top and bottom, please install the heat insulation deflector.

Rated current level	Installation Size	
	Vertical height	Horizontal width
≤32A	≥100mm	May not be required
32A-60A	≥200mm	≥50mm

## 3.2 Electrical Installation

### 3.2.1 Peripheral electrical components selection guide

Table 3-1 CT10M product peripheral electrical components selection guide

Product Model	Vacant A	Contactors A	Input side main circuit conductor mm <sup>2</sup>	Output side main circuit conductor mm <sup>2</sup>	Control Loop conductors mm <sup>2</sup>
CT10M-2S04P8B	10	9	2.5	2.5	1.0
CT10M-2S0008B	10	9	4	2.5	1.0
CT10M-2S0010B	16	12	6	4	1.0

Product Model	Vacant A	Conta ctors A	Input side main circuit conductor mm <sup>2</sup>	Output side main circuit conductor mm <sup>2</sup>	Control Loop conductors mm <sup>2</sup>
CT10M-2S0013B	20	18	6	4	1.0
CT10M-2T0017B	20	18	6	4	1.0
CT10M-2T0025B	40	32	6	6	1.0
CT10M-2T0032B	50	40	10	10	1.0
CT10M-2T0037B	63	50	10	10	1.0
CT10M-2T0045B	63	50	10	10	1.0
CT10M-4T02P5B	10	9	2.5	2.5	1.0
CT10M-4T04P2B	10	9	2.5	2.5	1.0
CT10M-4T05P6B	10	9	2.5	2.5	1.0
CT10M-4T09P4B	16	12	4	4.0	1.0
CT10M-4T0013B	20	18	4	4.0	1.0
CT10M-4T0017B	20	18	4	4.0	1.0
CT10M-4T0025B	40	32	6	6.0	1.0
CT10M-4T0032B	50	40	10	10	1.0
CT10M-4T0037B	63	50	10	10	1.0
CT10M-4T0045B	63	50	10	10	1.0
CT10M-4T0060B	100	65	16	16	1.0
CT10M-4T0075B	100	80	16	16	1.0
CT10M-4T0090B*	125	95	16	16	1.0
CT10M-4T0110B*	160	150	25	25	1.0
CT10M-4T0150	225	185	35	35	1.0
CT10M-4T0176	250	225	50	50	1.0
CT10M-4T0210	315	265	70	70	1.0
CT10M-4T0253	350	330	70	70	1.0
CT10M-4T0310	400	330	95	95	1.0
CT10M-4T0350	500	400	95	95	1.0
CT10M-4T0380	500	400	95	95	1.0
CT10M-4T0430	630	500	120	120	1.0
CT10M-4T0470	630	500	120	120	1.0
CT10M-4T0520	800	630	150	120	1.0
CT10M-4T0590	800	630	95*2	95*2	1.0
CT10M-4T0650	1000	800	120*2	120*2	1.0
CT10M-4T0725	1250	800	120*2	120*2	1.0



### 3.2.2 External Wiring

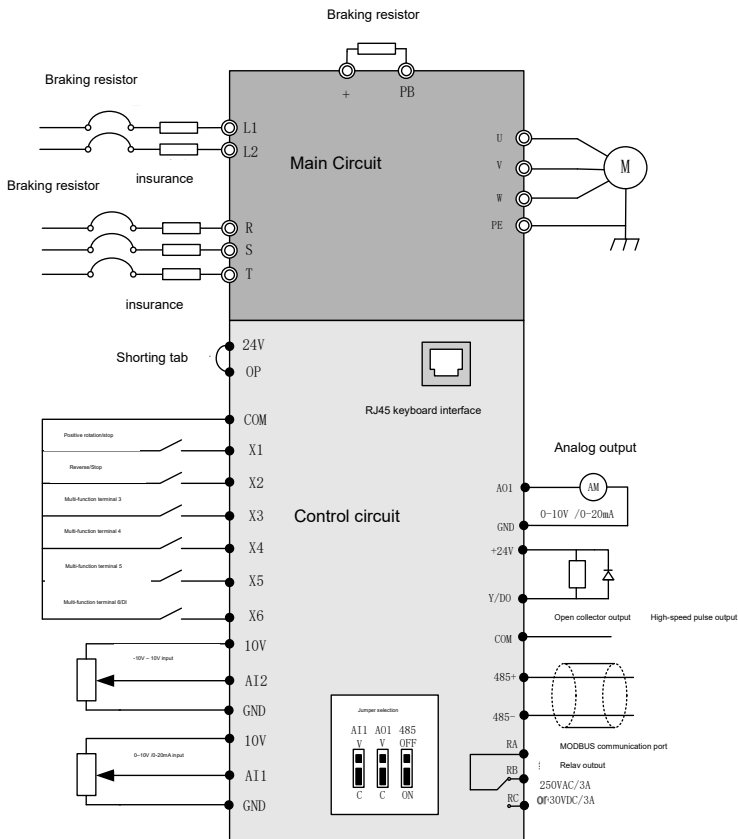



Figure 3-2 Typical wiring diagram of CT10M products

**Caution.**

- 1) Terminal  $\odot$  indicates the main circuit terminal, and  $\bullet$  indicates the control circuit terminal.
- 2) Built-in brake unit is optional for each model of CT10M series.
- 3) The model number followed by "B" indicates that it comes with a brake unit.
- 4) The braking resistors are selected according to the user's needs, see the braking resistor selection guide for details.
- 5) Signal lines and power lines must be separated, and if the control cable and power cable cross, they should be crossed at an angle of 90 degrees as far as possible. The analog signal line should preferably be shielded twisted pair, and the power cable should be shielded three-core cable (its

specification should be one grade larger than the normal motor cable) or follow the user manual of the product.

3.2.3 Main circuit terminals and wiring

	<b>Danger</b>
1	Make sure the power switch is OFF before wiring operation, otherwise an electric shock accident may occur!
2	The wiring personnel must be professionally trained, otherwise it may cause harm to the equipment and the person!
3	Must be reliably grounded, otherwise there is the risk of electric shock or fire!

	<b>Attention</b>
1	Make sure the input power is the same as the product's rating, otherwise damage the product!
2	Make sure the motor and the product are compatible, otherwise the motor may be damaged or cause product protection!
3	It is not possible to connect the power supply to the U, V and W terminals, otherwise the product will be damaged!
4	Do not connect the braking resistor directly to the DC bus (+), (-), otherwise it will cause a fire!

1) Three-phase 380V specification inverter main circuit terminals

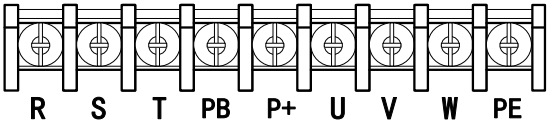

Figure 3-3 CT10M series three-phase 380V inverter main circuit terminal arrangement

(2) Single-phase / three-phase 220V specifications inverter main circuit terminals

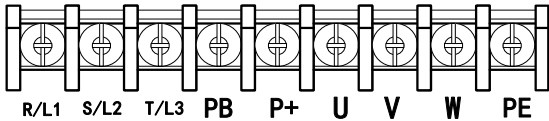

Figure 3-4 CT10M series single-phase/three-phase 220V series inverter main circuit terminal arrangement diagram

Terminal Marking	Name	Description
R/S/T L1/L2/L3	4T/2T series power input terminals	AC input three-phase power connection point single-phase 220V AC power connection point
P+, PB	Brake resistor connection terminal	Connecting the braking resistor
U, V, W	Product output terminals	Connecting three-phase motors
PE	Grounding terminal	Grounding terminal

**3.2.4 CT10M series product main circuit terminal wiring requirements.**

3.2.4.1 Wiring operations must be performed by professionally qualified personnel, otherwise there is a risk of electric shock or social security damage.

3.2.4.2 Confirm that the input power is completely disconnected before wiring operations, otherwise there is a risk of electric shock.

3.2.4.3 All wiring and lines shall comply with EMC and safety standards.

3.2.4.4 Terminal wiring screws or bolts must be tightened, otherwise there is a risk of damage to the equipment.

3.2.4.5 It is prohibited to connect the AC 220VAC voltage level signal to the terminals outside the control terminals RA, RB and RC.

**3.2.5 Control terminals and wiring**

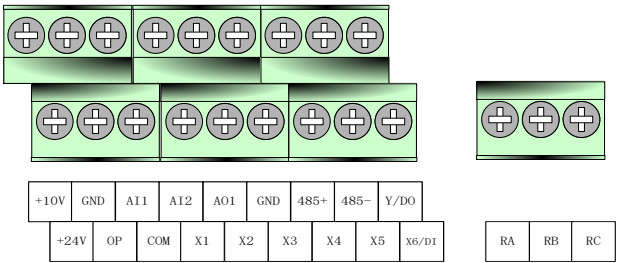

Figure 3-5 CT10M series inverter control circuit terminal layout

**Control terminal function description.**

**Table 3-2 CT10M product control terminal function description**

Category	Terminal Symbols	Terminal Name	Function Description
Power supply	+10V-GND	External +10V power supply	Provide +10V power supply to the outside, maximum output current: 10mA Used as an external potentiometer working power supply, resistance range: 1kΩ~50kΩ
	+24V-COM	External +24V power supply	Provide +24V power supply to the outside, generally used as the working power of digital input and output terminals and external sensor power supply, maximum output current: 200mA
	OP	External power input terminal	Choose to connect to +24V or COM through the metal jumper on the control board terminal, and the factory default is to connect to +24V. When using external signals to drive X1~X6, the OP needs to be connected to an external power supply and the shorting metal tab should be removed.
Model to be Entered	AI1-GND	Analog input terminal 1	1、Input voltage range: DC 0V~10V/4mA~20mA, jumper decision. 2、 Input impedance: 100kΩ
	AI2-GND	Analog input terminal 2	1、 Input range: DC -10V~10V 2、 Input impedance: 100kΩ for voltage input and 500Ω for current input.
Number Word Entered	X1-COM	Digital input 1	1、 Optical coupled isolation, compatible with bipolar input 2、 Input impedance: 4.7kΩ 3、 Voltage range at level input: 9V~30V
	X2-COM	Digital input 2	
	X3-COM	Digital input 3	
	X4-COM	Digital input 4	
	X5-COM	Digital input 5	
	X6-COM	High-speed pulse input terminal	In addition to having the functions of X1~X5, it can also be used as a high-speed pulse input channel. Maximum input frequency: 50kHz
Simulation Output	AO1-GND	Analog output 1	The voltage or current output is determined by the AO1 jumper selection on the control board. Output voltage range: 0V~10V Output current range: 0mA~20mA
Number Word Entered	Y/DO-COM	Digital output 1 (compatible with high-speed output)	Optically isolated, bipolar open collector output Output voltage range: 0V~24V Output current range: 0mA~50mA Note: The digital output ground GND is internally isolated from the digital input ground COM.
Relay Output	RA-RB	Normally closed terminal	Contact drive capability. AC250V, 3A; DC 30V, 3A.

Category	Terminal Symbols	Terminal Name	Function Description
	RA-RC	Frequently Open Ends	
Communication Port	485+/485-	Communication Interface	Transmission rate: 4.8K/9.6K/19.2K/38.4K/57.6K/115.2Kbps Maximum distance of 500 meters (using standard network cable)
Keyboard	CN3	External keyboard interface	The maximum communication distance is 3 meters when connecting the operation panel with standard network cable.

### 3) Control terminal screws and wiring specifications:

Cable Type	Cable specification (mm <sup>2</sup> )	Screws	Torque (kgf-cm)
Shielded Cable	1.0	M3	5±0.5

## 3.3 Control board wiring instructions

### Instructions for using analog input and output terminals

The voltage signal of analog input and output is especially vulnerable to external interference, so generally use shielded cable transmission, and the wiring distance is as short as possible, and the shielding layer is well grounded against the inverter end, and the transmission distance should not exceed 20m as far as possible.

The control cable should be kept at a distance of more than 20cm from the main circuit and strong power lines, avoiding parallel placement with strong power lines, and when crossed with strong power lines, vertical wiring is recommended to prevent the inverter from malfunctioning due to interference.

In the case of serious interference with the analog input and output signals, a filtering capacitor or ferrite core is required on the analog signal source side.

### Switching input and output terminals use instructions

Switching input and output signals generally use shielded cable transmission, and wiring distance as short as possible, and the shielding layer against the inverter end of a good ground, the transmission distance should not exceed 20 m. When elected to use the active mode drive, the power supply crosstalk to take the necessary filtering measures, usually recommended to use dry contact control mode.

When wiring, the control cable should be kept at a distance of more than 20cm from the main circuit and the strong power lines, and avoid parallel placement with the strong power lines. If crossover with the strong power lines cannot be avoided, it is recommended to use vertical wiring to prevent the inverter from malfunctioning due to interference.

### 3.3.1 Instructions for using the switching input terminals

#### ◆ Dry contact method

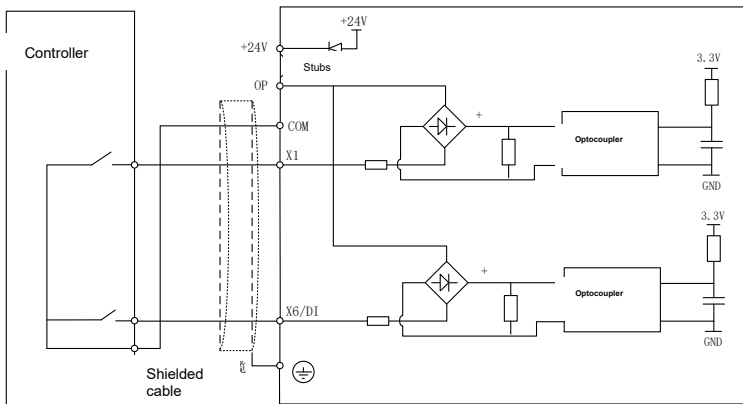

Figure 3-7 Using internal power dry contact method

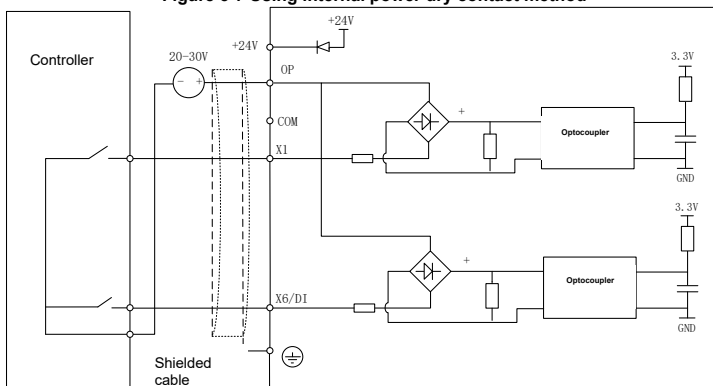

Figure 3-8 Using external power dry contact method

When using external power supply, the short circuit piece between +24V and OP must be removed, otherwise the product will be damaged; the voltage range of external power supply is DC20~30V, otherwise normal operation cannot be guaranteed and may even damage the product.

#### ◆ Open collector NPN wiring method

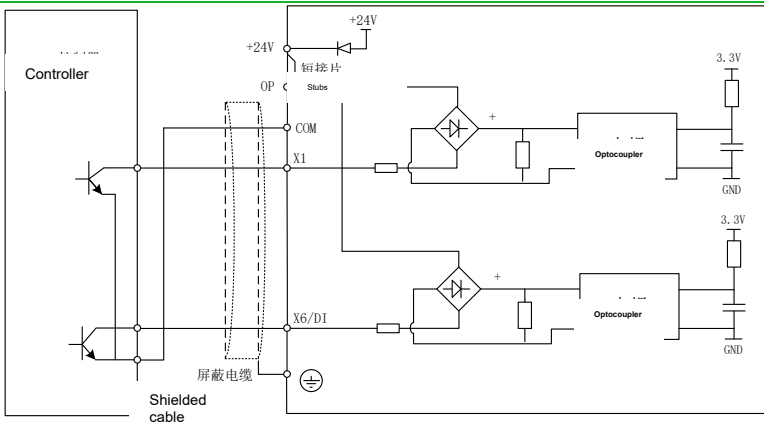

Figure 3-9 Using internal power supply open collector NPN wiring method

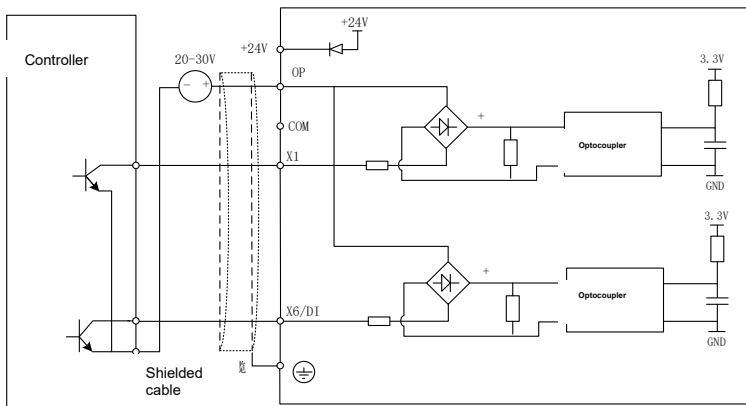

Figure 3-10 Using external power supply open collector NPN wiring method

When using external power supply, the short circuit piece between +24V and OP must be removed, otherwise the product will be damaged; the voltage range of external power supply is DC20~30V, otherwise normal operation cannot be guaranteed and may even damage the product.

◆ Open collector PNP wiring method

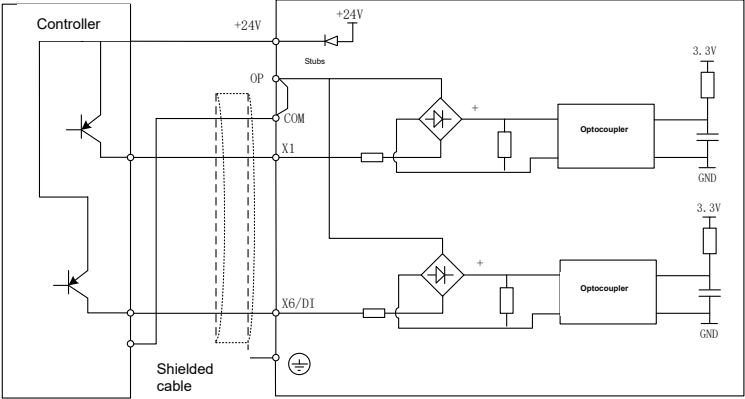

Figure 3-11 Using internal power supply open collector PNP wiring method

When using PNP wiring method, the shorting piece between +24V and OP must be removed and reconnected to between OP and COM, otherwise it cannot work properly.

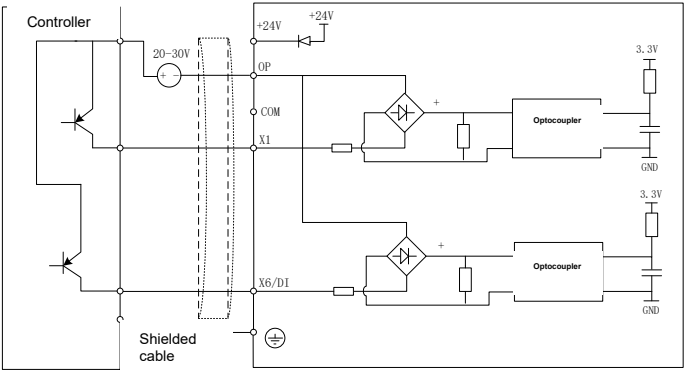
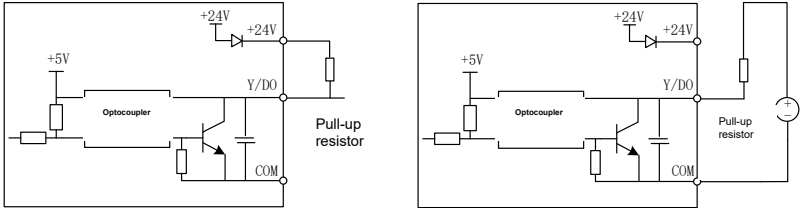

Figure 3-12 Open-collector PNP wiring using external power supply

When using external power supply, the short circuit piece between +24V and OP must be removed, otherwise the product will be damaged; the voltage range of external power supply is DC20~30V, otherwise normal operation cannot be guaranteed and may even damage the product.

3.3.2 Instructions for using the switch output terminal





a) Using internal power supply b) Using external power supply

**Figure 3-13 Wiring method when Y/DO terminal is connected to pull-up resistor output**

When the Y/DO terminal is set to pulse output, it can output 0~50kHz pulse signal.

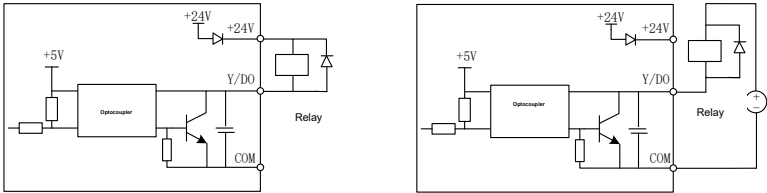

a) Using internal power supply b) Using external power supply

**Figure 3-14 Wiring method when Y/DO terminal drives relay**

1. When using the relay coil voltage is lower than 24V, it is necessary to add resistance between the relay and output terminal to divide the voltage according to the coil impedance. ,  
Relay output terminal wiring instructions
2. CT10M series inverter control board has a set of programmable relay dry contact outputs.
3. The relay contacts are RA/RB/RC, where RA and RB are normally closed contacts and RA and RC are normally open contacts, whose function is defined in the function code.
4. if the drive inductive load (such as electromagnetic relays or contactors), should be installed with surge voltage absorption circuit, such as RC absorption circuit (note that its leakage current should be less than the holding current of the controlled contactor or relay), varistor or current-continuing diode (for DC electromagnetic circuit, installation must pay attention to polarity). Absorption circuit components should be installed close to the coil ends of the relay or contactor.

**3.3.3 Signal switching jumper switch function description**

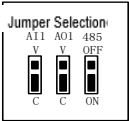

**Figure 3-15 Signal switching jumper switch diagram**

Marking	Function	Factory settings
485	485 Terminating resistor selection: ON for 100Ω terminating resistor, OFF for no terminating resistor	OFF: No resistance
AI1	AI1 analog type selection: C is current input (0~20mA), V is voltage input (0~10V)	V: 0~10V
AO1	AO1 analog type selection: C is current output (0~20mA), V is voltage output (0~10V)	V: 0~10V

### 3.4 EMC problems in wiring

The working principle of the inverter determines that it will generate a certain amount of noise, which will affect and interfere with other equipment; at the same time, the weak electrical signals inside the inverter are also susceptible to interference from the inverter itself and other equipment, in order to reduce or eliminate the interference of the inverter to the outside world and the interference of the inverter by the outside world, this section on the suppression of noise, grounding treatment, the suppression of leakage current, the application of power supply filters to make some brief explanations in several aspects This section provides a brief explanation of noise suppression, grounding treatment, leakage current suppression, and power supply filter application.

#### 3.4.1 Noise suppression countermeasures

When the peripheral equipment and inverter share the same system power supply, the noise generated by the inverter will spread to other equipment in the same system through the power line and cause misoperation, the following measures can be taken at this time.

- 1) Adding an input noise filter to the input of the inverter.
- 2) Adding a power filter to the power input of the affected equipment.
- 3) Use isolation transformer to isolate the noise transmission path between other equipment and inverter.

The wiring of the peripheral equipment and the inverter forms a loop, which will cause the equipment to operate by mistake. At this time, if the grounding of the equipment is disconnected, it will reduce the false operation.

- 1) Easily affected equipment and signal lines should be installed as far away from the inverter as possible.
- 2) The signal line should use shielded cable and the shield layer is reliably grounded, or the signal line cable can be set into the metal tube, the distance between the metal tube is at least 20cm, and should be as far as possible from the inverter and its peripheral devices and cables, avoid the signal line, power line parallel wiring or bundled with the power line into a bundle wiring.

Signal lines should be kept orthogonal to the crossing when they must cross power cables.

- 3) The motor cable line should be placed in a larger thickness of the barrier, such as the placement of more than 2mm thickness of the pipe or buried in a cement tank, or the power line can be placed in a metal tube and grounded with a shielded cable.
- 4) Use 4-core motor cable, one of which is grounded at the near end of the inverter, and the other side is connected to the motor housing.
- 5) The input and output of the inverter are equipped with radio noise filters and linear noise filters such as ferrite common mode chokes to suppress the radiation noise of the power line.

### 3.4.2 Grounding treatment

Recommend the use of special grounding as follows.

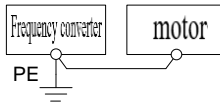

**Figure 3-16 Grounding treatment**

1. the largest possible standard size of grounding cable should be used to reduce the impedance of the grounding system.
2. The ground wire is as short as possible; and the grounding point is as close as possible to the inverter
3. four-core motor cable in a wire should be grounded in the inverter side, the other side connected to the motor grounding terminal, if the motor and inverter have a special grounding pole, the effect is better.
4. When the grounding end of each part of the system is connected together, the leakage current becomes a noise source and will affect other equipment in the system, so the grounding end of the inverter and other equipment susceptible to interference need to be separated.
5. the arrangement of grounding cables should be far from the noise sensitive equipment input and output wiring.

### 3.4.3 Leakage current suppression

The leakage current flows through the interline and ground distribution capacitors on the input and output side of the inverter, and its size is related to the capacitance of the distribution capacitor and the carrier frequency. The leakage current is divided into two types: leakage current to ground and leakage current between lines.

1. Leakage current to ground is not only circulating inside the inverter system, it may affect other equipment because of the ground loop, and these leakage currents may cause the leakage protector and other equipment to malfunction. The higher the carrier frequency of the inverter, the greater the leakage current to ground; the longer the motor cable, the greater the parasitic capacitance, the greater the leakage current to ground. Therefore, reducing the carrier frequency and using the shortest possible motor cable is the most direct and effective way to suppress the leakage current to ground.
2. flowing through the inverter output side of the cable between the interline leakage current, its high harmonics will accelerate the aging of the cable, but also may make other equipment misoperation. The higher the carrier frequency of the inverter, the greater the interline leakage current; the longer the motor cable, the greater the parasitic capacitance, the greater the interline leakage current. Therefore, reducing the carrier frequency and choosing the shortest possible motor cable is the most direct and effective way to suppress the leakage current to ground. Increasing the output reactor can also effectively suppress the size of the interline leakage current.

### 3.4.4 The use of power supply filters

Frequency converter belongs to the equipment that can produce strong interference and sensitive to external interference, it is recommended to use power filter. The following points need to be noted when using.

1. The filter body shell should be reliably grounded.
2. the input and output lines of the filter are as far away from each other as possible to avoid coupling between them.

3, the filter as far as possible against the inverter end, and the filter and inverter must be connected to the same common ground.

## Chapter 4 Operation and Display

### 4.1 Operation and display interface introduction

With the operation panel, you can modify the functional parameters of the product, monitor the working status of the product and control the operation of the product (start, stop), etc. Its appearance and functional area are shown in the figure below.

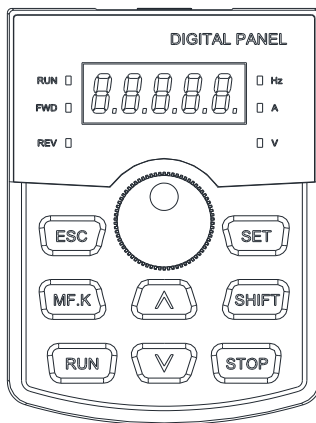

Figure 4-1 Schematic diagram of the operation panel

#### 1) Status indicator light description.

**FWD/REV:** When stopping, FWD light is on to indicate that the product is in positive rotation command; when running, it indicates positive rotation operation status; when FWD is flashing, it indicates that the product is switching from positive rotation status to reverse rotation status. When stopped, REV light is on, it means the product reversing command is valid, or reversing running state, when REV is flashing, it means the product is switching from reversing state to forward state.

#### 2) Unit indicator.

Hz frequency unit **A** current unit **V** voltage unit

**RMP (Hz+A)** speed unit % **(A+V)** percent

3) Digital display area.

The 5-digit LED display shows the set frequency, output frequency, various monitoring data and alarm codes, etc.

4) Keyboard button description table

**Table 4-1 Keypad Menu**

Button	Name	Function
<b>ESC/PRG</b>	Programming Keys	First-level menu entry or exit
<b>SET</b>	Confirm button	Step-by-step access to the menu screen and confirmation of setting parameters
△	Incremental keys	Increment of data or function codes
▽	Decrease key	Decrement of data or function codes
<b>SHIFT/&gt;&gt;</b>	Shift key	In the stop display interface and the operation display interface, the display parameters can be cyclically selected; when modifying the parameters, the modification bit of the parameters can be selected
<b>RUN</b>	Run button	For running operations in keyboard operation mode
<b>STOP</b>	Stop/Reset	When running state, press this key can be used to stop running operation; when fault alarm state, it can be used to reset operation, the characteristics of this key are governed by function code F7-16.
<b>MF.K</b>	Multi-function selection keys	Function switching selection according to F7-00

## 4.2 Function code view modification method description

The parameter group of CT10M series inverter contains a secondary menu structure, which can be modified and set through the operation panel. The steps for setting and modifying the parameters are as follows.

A. In the monitoring state, press the key "**ESC/PRG**" to enter the function code parameter display state.

B. In the parameter code display state, by "**SHIFT/>>**" button, the parameter function code parameter bit flashes, then the current flashing bit data can be modified.

C. Modify the blink parameter group to modify the target function code by using the /△▽ button.

D. "**SET**" button to enter the parameter function code.

E. Modify to the target parameter value, "SET" button, confirm the modified parameter value.

F. After the parameter modification is completed, the current display function code automatically jumps to the next valid display function code to complete the parameter modification.

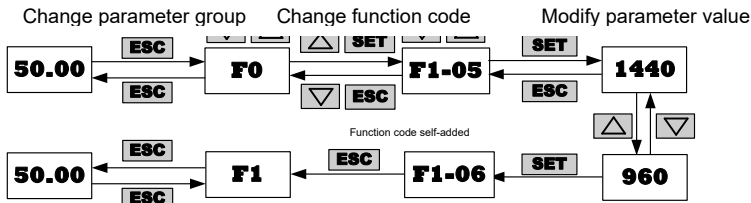

Figure 4-2 Parameter modification flow chart

## 4.3 Monitoring status display

### 4.3.1 Monitoring parameter switching in the shutdown state

In the stop state, the set frequency is displayed by default, you can switch to display other parameters by setting F7-05 parameter and "SHIFT/>>>" key. If we want to see the bus voltage in addition to the set frequency in the stop state, we set F7-05=0001 (the setting method refers to the setting method of the function code parameter). By "SHIFT/>>>" key, you can switch the display content in the shutdown state determined by F7-05.

### 4.3.2 Switching of monitoring parameters in the operating state

In the running state, the default display shows the running frequency high, and when the "SHIFT/>>>" button is pressed, it switches to the display value set by F7-03 and F7-04. If the bus voltage value needs to be monitored during operation, the F7-03 digit BIT2 is set to 1, then it is switched to the bus voltage value by "SHIFT/>>>" during operation.

### 4.3.3 Direct modification of the digital frequency

In the shutdown, fault or operation state, if the digital function terminal UP/DOWN is valid, or /  $\Delta$   $\nabla$  on the operation panel, it directly enters the digital frequency parameter modification state, and the modified frequency, is directly written into the F0-04 parameter group.

# Chapter 5 Basic operation and commissioning

The basic commissioning of the inverter mainly includes the frequency command setting of the inverter, the control of start and stop, and the simple commissioning and operation of the inverter-controlled motor can be realized according to the following contents.

## 5.1 Rapid commissioning process

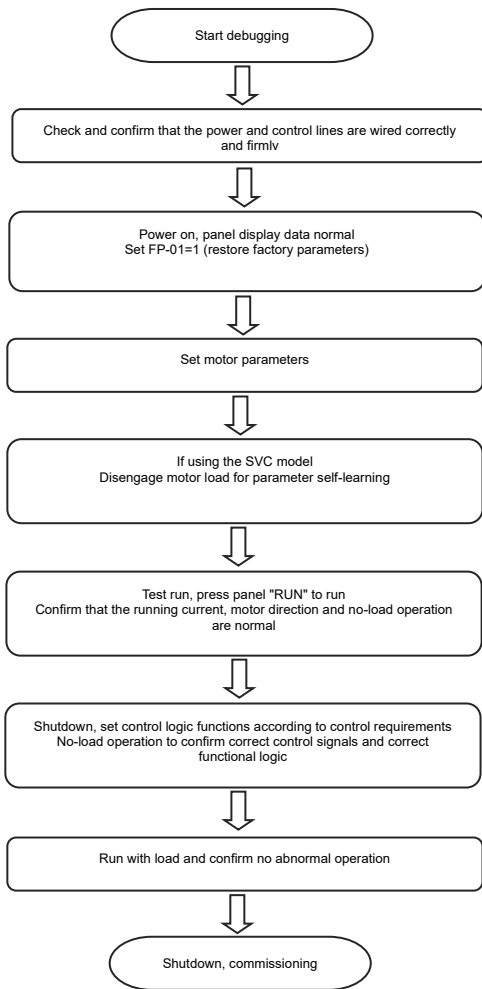

## 5.2 Introduction to common functions

### 5.2.1 Confirmation before power on

Please be sure to check the following items before turning on the power.

Projects	Content
Confirmation of power supply voltage	Please confirm if the power supply voltage is correct: single-phase AC220V 50/60Hz Three-phase AC380V~480V 50/60Hz
	Please wire the power input terminals (R/S/T) (L1/L2/L3) reliably.
	Confirm that the inverter and motor are properly grounded
Connection confirmation of inverter output terminal and motor terminal	Make sure the connection between the output terminal (U/V/W) and the motor terminal is secure.
Confirmation of connection with inverter control circuit terminals	Make sure that the control circuit terminals and other control devices are securely connected.
Status confirmation of inverter control terminals	Make sure that the control circuit terminals are all OFF.
Load Confirmation	Please make sure that the motor is not connected to the mechanical system because it is not in the no-load condition

### 5.2.2 Display status confirmation after power on

When the power is turned on, the operator in the normal state is displayed as shown below.

Status	Show	Description
Normal time	50.00	Factory default display is digital setting 50.00Hz
In case of failure	Er.XX	The inverter is shut down when the fault occurs, and the type of fault is displayed

### 5.2.3 Parameter initialization

The settings of the inverter can be restored to the factory settings, and after initialization, the FP-01 parameter values are automatically zeroed.

Parameter initialization	Factory value: 0	Description	
FP-01	0	No operation	
	1	Restore factory parameters Motor parameters are not included	Inverter function parameters are restored to factory values, but not including motor parameters
	2	Clear Recorded Information	Clear the inverter fault log information.



### 5.2.4 Selecting the motor control method

Function Code	Description	Applications
F0-01. Select motor control method	Set to 0: SVC vector control without speed sensor	Open-loop vector control for the usual high-performance control situations.
	Set to 2: V/F control (speed open-loop control)	Suitable for lighter loads.

### 5.2.5 Selecting the start/stop command channel

Select the input channel for inverter control commands. The control commands include: start, stop, forward, reverse, and jog, etc.

Command command selection	Factory value: 0	Description
F0-02	0	Operation Panel Operation command control by RUN, STOP/RES keys on the operation panel
	1	Connector Operation command control by multi-function input terminal functions FWD, REV, JOGF, JOGR, etc.
	2	Communication Operation commands are given by the host computer via communication

# Chapter 6 Functional parameters table

## 6.1 Summary table of function code groups of CT10M series inverters.

Classification	Function code sets
Group F: Operation parameter setting	F0: Basic function group
	F1: Motor parameter setting group
	F2: Control performance parameter setting group
	F3: V/F control curve parameter setting group
	F4: Analog/digital signal input setting group
	F5: Analog/digital signal output setting group
	F6: Start/stop parameter setting group
	F7: Display parameter setting group
	F8: Frequency auxiliary setting parameter group
	F9: Protection function parameter group
	FA: PID closed-loop function parameter group
	FC: Multi-step speed, PLC function setting group
	Fd: Communication parameter group
	FF: Password parameter setting group
FP: Function code management parameter group	
P group: industry non-standard parameter setting	P0: Torque control parameter group
	P5: Control optimization parameter set
Group U: Surveillance	U0: Status monitoring parameter group

### Change the attribute description.

★ Parameters can be changed during operation, shutdown state, not by the keypad and in case of parameter lock.

★ Parameters can be changed in the shutdown state, not by the keypad and in the case of parameter locking, and cannot be changed in the running state.

● Monitoring parameters, which cannot be changed.

## 6.2 Summary table of functional parameters

Function Code	Name	Setting range	Factory value	Change
<b>Group F0 Basic Function Group</b>				
F0-00	GP Type Display	1: G type (constant torque load model)	1	●
		2: P type (fan, pump type load)		
F0-01	1st motor control method	0: Vector control without speed sensor (SVC)	2	★
		1: Vector control with speed sensor (FVC)		
F0-02	Run command selection	2: V/F control	0	★
		0: Operator panel		
		1: Terminal		
		2: Communication		

F0-03	Main frequency source input selection	0: Digital setting (no memory for power down)	4	★
		1: Digital setting (power-down memory)		
		2: AI1		
		3: AI2		
		4: Panel Potentiometer		
		5: Pulse setting (X6)		
		6: Multi-segment command		
		7: Simple PLC		
		8: PID		
9: Communication given				
F0-04	Auxiliary frequency source input selection	Same definition as F0-03 (main frequency command input selection)	0	★
F0-05	Auxiliary frequency command range selection	0: relative to the maximum frequency	0	★
		1: Relative to the main frequency command		
F0-06	Auxiliary frequency command range selection	0%~150%	100%	★
F0-07	Primary and secondary frequency overlay selection	Digit: Frequency command selection	0	★
		0: Main frequency instruction 1: Main and auxiliary operation result		
		2: Main frequency command and auxiliary frequency command switching		
		3: Main frequency instruction and main and auxiliary operation result switching		
		4: Auxiliary frequency instruction and the main and auxiliary operation results switch		
		Ten bits: frequency command primary and secondary operation relationship		
		0: primary + secondary 1: primary - secondary		
		2: The maximum value of the two		
3: Minimum value of the two				
F0-08	Digital frequency setting	0.00Hz~maximum frequency (F0-10)	50.00Hz	★
F0-09	Running direction	0: Positive rotation operation	0	★
		1: Reverse operation		
F0-10	Maximum frequency	Upper limit frequency ~500.00Hz	50.00Hz	★
F0-11	Upper limit frequency command selection	0: F0-12 setting	0	★
		1: AI1		
		2: AI2		
		3: Panel Potentiometer		
		4: Pulse setting		
5: Communication given				

<b>F0-12</b>	Upper limit frequency	Lower limit frequency F0-14~Maximum frequency F0-10	<b>50.00Hz</b>	★
<b>F0-13</b>	Upper frequency bias	0.00Hz~maximum frequency F0-10	<b>0.00Hz</b>	★
<b>F0-14</b>	Lower limit frequency	0.00Hz~upper limit frequency F0-12	<b>0.00Hz</b>	★
<b>F0-15</b>	Carrier frequency	0.5kHz~16.0kHz	<b>Model</b>	★
<b>F0-16</b>	Carrier frequency adjusts with load size	0: No	<b>1</b>	★
		1: <b>Yes</b>		
<b>F0-17</b>	Acceleration time 1	0.0~6500.0	<b>Model</b>	★
<b>F0-18</b>	Acceleration time 1	0.0~6500.0	<b>Model</b>	★
<b>F0-19</b>	Acceleration and deceleration time units	0: 1 second	<b>1</b>	★
		1: 0.1 second		
		2: 0.01 seconds		
<b>F0-21</b>	Auxiliary frequency command bias frequency during superposition	0.00Hz~maximum frequency F0-10	<b>0.00Hz</b>	★
<b>F0-23</b>	Digital set frequency stop memory selection	0: No memory 1: Memory	<b>0</b>	★
<b>F0-25</b>	Acceleration and deceleration time reference frequency	0: Maximum frequency (F0-10)	<b>0</b>	★
		1: Set frequency		
<b>F0-26</b>	Runtime frequency command UP/DOWN reference	0: Operating frequency 1: Set frequency	<b>0</b>	★
<b>F0-27</b>	Run command bundle master frequency command selection	Individual position: operation panel binding frequency source selection	<b>0</b>	★
		0: No binding		
		1: Digital setting frequency		
		2: AI1		
		3: AI2		
		4: Panel Potentiometer		
		5: Pulse setting (X6)		
		6: Multi-speed		
		7: Simple PLC		
		8: PID		
		9: Communication given		
		Ten bits: terminal binding frequency source selection		
		Hundred bits: communication binding frequency source selection		

F1 group Motor parameters				
F1-00	Motor type selection	0: Ordinary asynchronous motor	0	★
		1: Inverter asynchronous motor		
F1-01	Motor rated power	0.4KW~630KW	Model	★
F1-02	Motor rated voltage	1V ~ 1000V	Model	★
F1-03	Motor rated current	0.01A ~ 6553.5A	Model	★
F1-04	Motor rated frequency	0.01Hz ~ Maximum Frequency	Model	★
F1-05	Motor rated speed	1rpm ~ 65535rpm	Model	★
F1-06	Motor stator resistance	0.0001Ω ~ 65.535Ω (Inverter power ≤ 55kW)		★
		0.0001Ω ~ 6.5535Ω (Inverter power >55kW)		
F1-07	Motor rotor resistance	0.0001Ω ~ 65.535Ω (Inverter power ≤ 55kW)		★
		0.0001Ω ~ 6.5535Ω (Inverter power >55kW)		
F1-08	Motor leakage inductance resistance	0.01mH ~ 655.35mH (Inverter power ≤ 55kW) 0.001mH ~ 65.535mH (Inverter power >55kW)		★
F1-09	Motor mutual inductance resistance	0.1mH ~ 6553.5mH (Inverter power ≤ 55kW) 0.01mH ~ 655.35mH (Inverter power >55kW)		★
F1-10	Motor no-load current	0.01A ~ F1-03 (Inverter power ≤ 55kW)		★
		0.1A ~ F1-03 (Inverter power >55kW)		
F1-27	Number of encoder lines	1 ~ 65535	1024	★
F1-28	Encoder type	0: ABZ incremental encoder	0	★
		2: Rotary transformer		
F1-30	ABZ incremental encoder AB phase sequence	0: Positive	0	★
		1: Reverse		
F1-34	Number of pole pairs of resolver	1 ~ 65535	1	★
F1-36	Speed Feedback PG Disconnection Detection Time	0.0s: no action	0.0s	★
		0.1s ~ 10.0s		
F1-37	Tuning options	0: No operation	0	★
		1: Asynchronous machine stationary part parameter tuning		
		2: Asynchronous machine dynamic complete tuning		
		3: Asynchronous machine stationary complete tuning		
Group F2 Motor vector control parameters				
F2-00	Speed loop low speed proportional gain	1 ~ 100	30	★
F2-01	Speed loop low speed integration time	0.01s ~ 10.00s	0.50s	★
F2-02	Speed loop low speed switching frequency	0.00 ~ F2-05	5.00Hz	★
F2-03	Speed loop high speed proportional gain	1 ~ 100	20	★
F2-04	Speed loop high speed integration time	0.01s ~ 10.00s	1.00s	★
F2-05	Speed loop high speed switching frequency	F2-02 ~ Maximum frequency	10.00Hz	★

<b>F2-06</b>	Vector control differential gain	50% ~ 200%	<b>100%</b>	★
<b>F2-07</b>	SVC speed feedback filtering time	0.000s ~ 0.100s	<b>0.015s</b>	★
<b>F2-08</b>	Vector mode overexcitation gain	0-200	<b>100</b>	★
<b>F2-09</b>	Torque limit command selection in speed control mode	0: Function code F2-10 Setting	<b>0</b>	★
		1: AI1		
		2: AI2		
		3: Panel Potentiometer		
		4: Pulse (X6)		
		5: Communication given		
		6: MIN(AI1,AI2)		
		7: MAX(AI1,AI2)		
The full-scale range of options 1-7 corresponds to F2-10				
<b>F2-10</b>	Digital setting of upper torque limit in speed control mode	0.0% ~ 200.0%	<b>140%</b>	★
<b>F2-11</b>	Torque upper limit command selection in speed control mode (power generation)	0: Function code F2-12 setting (does not distinguish between electric and power generation)	<b>0</b>	★
		1: AI1		
		2: AI2		
		3: Panel Potentiometer		
		4: Pulse (X6)		
		5: Communication given		
		6: MIN(AI1,AI2)		
		7: MAX(AI1,AI2)		
8: Function code F2-12 Setting				
The full-scale range of options 1-7 corresponds to F2-12				
<b>F2-12</b>	Digital setting of upper torque limit in speed control mode (power generation)	0.0% ~ 200.0%	<b>150%</b>	★
<b>F2-13</b>	Excitation adjustment proportional gain	0 ~ 60000	<b>2000</b>	★
<b>F2-14</b>	Excitation regulation integral gain	0 ~ 60000	<b>1300</b>	★
<b>F2-17</b>	Speed Ring Points Properties	Individuals: Integral separation	<b>0</b>	★
		0: Invalid		
		1: Effective		
<b>F2-18</b>	Vector mode overexcitation action selection	0: No enable 1: Deceleration enable only 2: Constant speed and deceleration enable	<b>1</b>	★
<b>F2-19</b>	Overmodulation enable selection	0: Not enabled 1: Enabled	<b>0</b>	★
<b>F2-20</b>	Voltage over modulation factor	100-110%	<b>105</b>	★
<b>F2-21</b>	Maximum torque coefficient in the weak magnetic region	50-200	<b>100</b>	★
<b>F2-22</b>	Power generation torque enable selection in speed mode	0: Invalid 1: Valid	<b>0</b>	★

Group F3 V/F control parameters				
F3-00	V/F curve setting	0: Straight line V/F		
		1: Multi-point V/F		★
		2-9: Reserved	0	
		10: V/F fully separated mode		
		11: V/F semi-separate mode		
F3-01	Torque boost	0.0%: (no torque boost)	Model	★
		0.1% ~ 30.0%		
F3-02	Torque boost cut-off frequency	0.00Hz ~ Maximum Frequency	50.00Hz	★
F3-03	Multi-point V/F frequency point 1	0.00Hz ~ F3-05	0.00Hz	★
F3-04	Multi-point V/F voltage point 1	0.0% ~ 100.0%	0.00%	★
F3-05	Multi-point V/F frequency point 2	F3-03 ~ F3-07	0.00Hz	★
F3-06	Multi-point V/F voltage point 2	0.0% ~ 100.0%	0.00%	★
F3-07	Multi-point V/F frequency point 3	F3-05 ~ Motor rated frequency (F1-04)	0.00Hz	★
F3-08	Multi-point V/F voltage point 3	0.0% ~ 100.0%	0.00%	★
F3-10	V/F Overexcitation gain	0 ~ 200	100	★
F3-11	V/F Oscillation rejection factor	0 ~ 100	40	★
F3-13	V/F separated voltage source	0: Digital setting (F3-14)		★
		1: AI1		
		2: AI2		
		4: PULSE pulse setting (X6)		
		5: Multi-segment command	0	
		6: Simple PLC		
		7: PID		
		8: Communication given		
		Note: 100.0% corresponds to the rated voltage of the motor		
F3-14	V/F separated voltage digital setting	0V ~ Motor rated voltage	0V	★
F3-15	Voltage acceleration time for V/F separation	0.0s ~ 1000.0s	0.0s	★
		Note: indicates the time to change from 0V to the rated motor voltage		
F3-16	Voltage deceleration time for V/F separation	0.0s ~ 1000.0s	0.0s	★
		Note: indicates the time to change from 0V to the rated motor voltage		
F3-17	V/F separation stop method selection	0: Frequency/voltage independently reduced to 0	0	★
		1: Voltage is reduced to 0 and then frequency is reduced		
F3-18	Overcurrent suppression level	50~200%	150%	★
F3-19	Overcurrent suppression effectiveness selection	0: Invalid 1: Valid	1	★
F3-20	Overcurrent suppression gain	0~100	20	★

F3-21	Over loss of speed action current compensation factor	50~200%	50%	★
F3-22	Overvoltage stall action voltage	650.0V~800.0V	720	★
F3-23	Overvoltage stall enable	0: Invalid	1	★
		1: Effective		
F3-24	Overvoltage stall suppression frequency gain	0~100	30	★
F3-25	Overvoltage stall suppression voltage gain	0~100	30	★
F3-26	Overvoltage stall speed maximum rise frequency limit	0~50Hz	5Hz	★
<b>Group F4 Input terminals</b>				
F4-00	X1 terminal function selection	0: No function	1	★
		1: Forward rotation operation FWD		
		2: Reverse run REV		
		3: Three-wire operation control		
		4: Positive rotation point movement (FJOG)		
		5: Reverse Jogging (RJOG)		
		6: Terminal UP		
		7: Terminal DOWN		
		8: Free parking		
		9: Fault reset (RESET)		
		10: Run Suspension		
		11: External fault normally open input		
		12: Multi-segment command terminal 1		
		13: Multi-segment command terminal 2		
		14: Multi-segment command terminal 3		
		15: Multi-segment command terminal 4		
		16: Acceleration and deceleration time selection terminal 1		
		17: Acceleration and deceleration time selection terminal 2		
		18: Frequency command switching		
		19: UP/DOWN setting clear		
		20: Control command switching terminal 1		
		21: Acceleration and deceleration prohibited		
		22: PID suspension		
		23: Simple PLC status reset		
		24: Pendulum frequency pause		
		25: Counter input		
		26: Counter reset		
		27: Length count input		
28: Length reset				



		29: Torque control prohibition		
		30: Pulse frequency input (valid for X6 only)		
		32: Immediate DC braking		
		33: External fault normally closed input		
		34: Frequency modification enable		
		35: PID action direction is reversed		
		36: External parking terminal 1		
		37: Control command switching terminal 2		
		38: PID points suspended		
		39: Master frequency and preset frequency switching		
		40: Auxiliary frequency and preset frequency switching		
		41: Motor terminal selection function		
		42: Retention		
		43: PID parameter switching		
		44: User-defined faults 1		
F4-01	X2 terminal function selection	45: User-defined fault 2	4	★
F4-02	X3 terminal function selection	46: Speed control/torque control switching	9	★
F4-03	X4 terminal function selection	47: Emergency stop	12	★
F4-04	X5 terminal function selection	48: External parking terminal 2	13	★
F4-05	X6 terminal function selection	49: Deceleration DC brake 50: This run time is cleared 51: Two-wire/three-wire switching 52: Prohibition of reversal 53-59: Functional retention	0	★
F4-10	DI filtering time	0.000s~1.000s	0.010s	★
F4-11	Terminal command method	0: Two-line type 1 1: Two-line type 2 2: Three-wire type 1 3: Three line type 2	0	★
F4-12	Terminal UP/DOWN change rate	0.001Hz/s~65.535Hz/s	1.00Hz/s	★
F4-13	AI curve 1 minimum input	0.00V~F4-15	0.00V	★
F4-14	AI curve 1 minimum input corresponding setting	-100.0%~+100.0%	0.00%	★
F4-15	AI curve 1 maximum input	F4-13~+10.0V	10.00V	★
F4-16	AI curve 1 maximum input corresponding setting	-100.0%~+100.0%	100.00%	★

F4-17	AI1 filtering time	0.00s-10.00s	0.10s	★
F4-18	AI curve 2 minimum input	0.00V-F4-20	0.00V	★
F4-19	AI curve 2 minimum input corresponding setting	-100.0%~+100.0%	0.00%	★
F4-20	AI curve 2 maximum input	F4-18~+10.0V	10.00V	★
F4-21	AI curve 2 maximum input corresponding setting	-100.0%~+100.0%	100.00%	★
F4-22	AI2 filtering time	0.00s-10.00s	0.10s	★
F4-23	AI curve 3 minimum input	-10.00V-F4-25	-10.00V	★
F4-24	AI curve 3 minimum input correspondence setting	-100.0%~+100.0%	-100.00%	★
F4-25	AI curve 3 maximum input	F4-23~+10.00V	10.00V	★
F4-26	AI curve 3 maximum input corresponding setting	-100.0%~+100.0%	100.00%	★
F4-27	AI3 filtering time	0.00s-10.00s	0.10s	★
F4-28	Minimum pulse input frequency	0.00kHz-F4-30	0.00kHz	★
F4-29	Minimum pulse input frequency setting	-100.0%~100.0%	0.00%	★
F4-30	Maximum pulse input frequency	F4-28-100.00kHz	50.00kHz	★
F4-31	The maximum pulse input frequency corresponds to the setting	-100.0%~100.0%	100.00%	★
F4-32	Pulse filtering time	0.00s-10.00s	0.10s	★
F4-33	AI curve selection	Individual position: AI1 curve selection	321	★
		1: Curve 1 (2 points, see F4-13~F4-16)		
		2: Curve 2 (2 points, see F4-18~F4-21)		
		3: Curve 3 (2 points, see F4-23~F4-26)		
		Ten bits: AI2 curve selection, same as above		
F4-34	AI below minimum input setting selection	Individual position: AI1 is below the minimum input setting selection	0	★
		0: Corresponds to the minimum input setting		
		1: 0.0%		
		Ten bits: AI2 is below the minimum input setting selection, as above		
F4-35	X1 delay time	0.0s-3600.0s	0.0s	★
F4-36	X2 delay time	0.0s-3600.0s	0.0s	★
F4-37	X3 Delay Time	0.0s-3600.0s	0.0s	★

F4-38	Digital input terminal X active mode selection 1	0: High level active	0	★
		1: Active low		
		Individual position: X1		
		Tenth position: X2		
		Hundred: X3		
		Thousands of bits: X4		
F4-39	Digital input terminal X active mode selection 2	0: High level active	0	★
		1: Active low		
		Individual: X6		
<b>Group F5 Output terminals</b>				
F5-00	Y/DO output function selection	0: Pulse output (DO)	0	★
		1: Switching output (Y)		
F5-01	Y terminal function selection (open collector output terminal)	0: No output	0	★
		1: Inverter running		
		2: Fault output (for the fault of free stop)		
		3: Frequency level detection1		
		4: Frequency arrival		
		5: In zero-speed operation (no output at shutdown)		
		6: Motor overload pre-warning		
		7: Inverter overload pre-alarm		
		8: Set the value of the note to reach		
		9: Specify the value of the notation to arrive		
		10: Length arrival		
		11: Simple PLC cycle completion		
		12: Cumulative running time reached		
		13: Frequency limited in		
		14: Torque limited in		
		15: Ready to run		
		16: AI1>AI2		
		17: Upper limit frequency reached		
		18: Lower limit frequency reached (no output at shutdown)		
		19: Undervoltage status		
		20: Communication settings		
		21: Reserved		
		22: Reservation		
23: Zero speed operation in 2 (output also when stopped)				

		24: Cumulative power-up time reached		
		25: Frequency level detection 2		
		26: Frequency 1 arrives		
		27: Frequency 2 arrives		
		28: Current 1 arrives		
		29: Current 2 arrives		
		30: Timed arrival		
		31: AI1 input overrun		
		32: Dropping load		
		33: Reverse running in		
		34: Zero current state		
		35: Module temperature reaches		
		36: Output current over limit		
		37: Lower limit frequency reached (shutdown also output)		
<b>F5-02</b>	Control board relay function selection (TA-TB-TC)	38: Alarm (all faults)	2	★
<b>F5-06</b>	DO output function selection	0: Operating frequency	0	★
		1: Set frequency		
		2: Output current		
		3: Motor output torque (absolute value, percentage relative to the motor)		
		4: Output power		
		5: Output voltage		
		6: Pulse input (100.0% corresponds to 100.0kHz)		
		7: AI1		
		8: AI2		
		9: Reserved		
		10: Length		
		11: Remember the value		
		12: Communication settings		
		13: Motor speed		
<b>F5-07</b>	AO output function selection	14: Output current (100.0% corresponds to 1000.0A)	0	★
<b>F5-08</b>	Reserved	15: Output voltage (100.0% corresponds to 1000.0V)	1	★
<b>F5-09</b>	DO output maximum frequency	16: Motor output torque (actual value, percentage relative to motor)	50.00kHz	★
<b>F5-10</b>	AO zero bias factor	0.01kHz~100.00kHz	0.00%	★
<b>F5-11</b>	AO Gain	0	1	★
		-10.00~+10.00		

F5-17	DO output delay time	0.0s~3600.0s	0.0s	★
F5-18	Relay output delay time	0.0s~3600.0s	0.0s	★
F5-20	DO output delay time	0.0s~3600.0s	0.0s	★
F5-22	DO output terminal active state selection	0: positive logic	0	★
		1: Anti-logic		
		Positions: FMR		
		Tenth place: RELAY1		
		Thousands: DO1		
<b>Group F6 Start/Stop Control</b>				
F6-00	Start-up method	0: Direct start	0	★
		1: Speed tracking restart		
		2: Pre-excitation start (AC asynchronous machine)		
		3: SVC Quick Start		
F6-01	Rotational speed tracking method	0: From stopping frequency	0	★
		1: Start with IFB		
		2: Start from the maximum frequency		
F6-02	Rotational speed tracking fast and slow	1~100	20	★
F6-03	Start-up frequency	0.00Hz~10.00Hz	0.00Hz	★
F6-04	Start frequency hold time	0.0s~100.0s	0.0s	★
F6-05	Start DC braking current/pre-excitation current	0%~100%	50%	★
F6-06	Start DC braking time/pre-excitation time	0.0s~100.0s	0.0s	★
F6-07	Acceleration and deceleration mode	0: Linear acceleration and deceleration	0	★
		1, 2: Dynamic S-curve acceleration and deceleration		
F6-08	S-curve start time ratio	0.0%~(100.0%-F6-09)	30.00%	★
F6-09	S-curve end time ratio	0.0%~(100.0%-F6-08)	30.00%	★
F6-10	Shutdown method	0: Slow down and stop 1: Free stop	0	★
F6-11	Stop DC braking starting frequency	0.00Hz~maximum frequency	0.00Hz	★
F6-12	Stop DC brake waiting time	0.0s~100.0s	0.0s	★
F6-13	Stopping DC braking current	0%~100%	50%	★
F6-14	Stopping DC braking time	0.0s~100.0s	0.0s	★
F6-15	Brake usage ratio	0%~100%	100%	★
F6-18	Rotational speed tracking current size	30%~200%	Model	★
F6-21	Demagnetization time (SVC valid)	0.00~5.00s	Model	★
<b>Group F7 Keyboard and Display</b>				
F7-00	Reserved			
F7-01	MF.K key function selection	0: MF.K invalid	0	★

		<p>1: Operating panel command channel and remote command channel (terminal command channel or communication command channel) switching</p> <p>2: Forward and reverse switching</p> <p>3: Positive rotation point movement</p> <p>4: Reversal of point movement</p> <p>5: Panel PID setting is valid</p>		
<b>F7-02</b>	STOP/RESET key function	<p>0: STOP/RES key stop function is only valid in the keyboard operation mode</p> <p>1: STOP/RES key stop function is effective for any operating channel</p>	1	★
<b>F7-03</b>	Operation display parameter 1	<p>0000~FFFF</p> <p>Binary setting.</p> <p>Individual selection XXXXXX (BIT 3-2-1-0)</p> <p>Bit00: Operating frequency 1(Hz)</p> <p>Bit01: Set frequency (Hz)</p> <p>Bit02: Busbar voltage (V)</p> <p>Bit03: Output voltage (V)</p> <p>Decimal selection XXXXXX (BIT 3-2-1-0)</p> <p>Bit04: Output current (A)</p> <p>Bit05: Output power (kW)</p> <p>Bit06: Output torque (%)</p> <p>Bit07: X terminal input status</p> <p>Hundred selection XXXXXX (BIT 3-2-1-0)</p> <p>Bit08: DO output status</p> <p>Bit09: AI1 voltage (V)</p> <p>Bit10: AI2 voltage (V)</p> <p>Bit11: Reserved</p> <p>Thousand bit selection XXXXXX (BIT 3-2-1-0)</p> <p>Bit12: Counting value</p> <p>Bit13: Length value</p> <p>Bit14: Load speed display</p> <p>Bit15: PID setting</p>	1F	★
<b>F7-04</b>	Operation display parameter 2	<p><b>0000~FFFF</b></p> <p><b>Binary setting.</b></p> <p>Individual selection XXXXXX (BIT 3-2-1-0)</p> <p>Bit00: PID feedback</p> <p>Bit01: PLC Stage</p>	0	★

		<p>Bit02: PULSE input pulse frequency (kHz)</p> <p>Bit03: Operating frequency 2 (Hz)</p> <p>Decimal selection XXXXXX (BIT 3-2-1-0)</p> <p>Bit04: Remaining runtime</p> <p>Bit05: AI1 voltage before correction (V)</p> <p>Bit06: AI2 voltage before correction (V)</p> <p>Bit07: Reserved</p> <p>Hundred selection XXXXXX (BIT 3-2-1-0)</p> <p>Bit08: Line Speed</p> <p>Bit09: Current power-on time (Hour)</p> <p>Bit10: Current running time (Min)</p> <p>Bit11: PULSE input pulse frequency (Hz)</p> <p>Thousand bit selection XXXXXX (BIT 3-2-1-0)</p> <p>Bit12: Communication setting value</p> <p>Bit13: Encoder feedback speed (Hz)</p> <p>Bit14: Master frequency X display (Hz)</p> <p>Bit15: Auxiliary frequency Y display (Hz)</p>		
<p><b>F7-05</b></p>	<p>Shutdown display parameters</p>	<p>0000~FFFF</p> <p>Binary setting.</p> <p>Individual selection XXXXXX (BIT 3-2-1-0)</p> <p>Bit00: Set frequency (Hz)</p> <p>Bit01: Bus voltage (V)</p> <p>Bit02: X input status</p> <p>Bit03: DO output status</p> <p>Decimal selection XXXXXX (BIT 3-2-1-0)</p> <p>Bit04: AI1 voltage (V)</p> <p>Bit05: AI2 voltage (V)</p> <p>Bit06: Reserved</p> <p>Bit07: Counting value</p> <p>Hundred selection XXXXXX (BIT 3-2-1-0)</p> <p>Bit08: Length value</p> <p>Bit09: PLC Stage</p> <p>Bit10: Load speed</p> <p>Bit11: PID setting</p> <p>Thousand bit selection XXXXXX (BIT 3-2-1-0)</p> <p>Bit12: PULSE input pulse frequency (kHz)</p>	<p><b>03</b></p>	<p>★</p>

F7-06	Load speed display factor	0.0001~6.5000	1	★
F7-07	Inverter module heat sink temperature	-20℃~120℃	-	●
F7-09	Cumulative running time	0h~65535h	-	●
F7-11	Function Version Number	Software Version Number	-	●
F7-12	Load speed display with fractional digits	Digits: the number of decimal places from U0-14	21	★
		0: 0 decimal places		
		1: 1 decimal place		
		2: 2 decimal places		
		3: 3 decimal places		
		Decimal places: U0-19/U0-29 decimal places		
		1: 1 decimal place		
2: 2 decimal places				
F7-13	Cumulative power-up time	0~65535 hours	-	●
F7-14	Cumulative power consumption	0~65535 degrees	-	●
<b>F8 group auxiliary functions</b>				
F8-00	Pointing operation frequency	0.00Hz~maximum frequency	2.00Hz	★
F8-01	Tap acceleration time	0.0s~6500.0s	20.0s	★
F8-02	Tap deceleration time	0.0s~6500.0s	20.0s	★
F8-03	Acceleration time 2	0.0s~6500.0s	Model determination	★
F8-04	Deceleration time2	0.0s~6500.0s	Model determination	★
F8-05	Acceleration time 3	0.0s~6500.0s	Model determination	★
F8-06	Deceleration time3	0.0s~6500.0s	Model determination	★
F8-07	Acceleration time 4	0.0s~6500.0s	0.0s	★
F8-08	Deceleration time4	0.0s~6500.0s	0.0s	★
F8-09	Jump frequency1	0.00Hz~maximum frequency	0.00Hz	★
F8-10	Jump frequency 2	0.00Hz~maximum frequency	0.00Hz	★
F8-11	Jump frequency amplitude	0.00Hz~maximum frequency	0.00Hz	★
F8-12	Forward and reverse rotation dead time	0.0s~3000.0s	0.0s	★
F8-13	Reverse Frequency Prohibition	0: Invalid 1: Valid	0	★
F8-14	Set frequency below the lower limit frequency operation mode	0: Operates at the lower frequency limit	0	★
		1: Shutdown		
		2: Zero speed operation		
F8-15	Sagging rate	0.00%~100.00%	0.00%	★
F8-16	Set cumulative power-up arrival time	0h~65000h	0h	★
F8-17	Set cumulative run arrival time	0h~65000h	0h	★
F8-18	Startup protection selection	0: No protection 1: Protection	0	★
F8-19	Frequency detection value1	0.00Hz~maximum frequency	50.00Hz	★



F8-20	Frequency detection lag rate1	0.0%~100.0% (FDT1 level)	5.00%	★
F8-21	Frequency arrival detection amplitude	0.0%~100.0% (maximum frequency)	0.00%	★
F8-22	Whether the jump frequency is effective during acceleration and deceleration	0: Invalid	0	★
F8-25	Acceleration time 1 and acceleration time 2 switching frequency points	0.00Hz~maximum frequency	0.00Hz	★
F8-26	Deceleration time 1 and deceleration time 2 switching frequency points	0.00Hz~maximum frequency	0.00Hz	★
F8-27	Terminal point-action priority	0: Invalid 1: Valid	0	★
F8-28	Frequency detection value2	0.00Hz~maximum frequency	50.00Hz	★
F8-29	Frequency detection lag rate2	0.0%~100.0% (FDT2 level)	5.00%	★
F8-30	Arbitrary arrival frequency detection value 1	0.00Hz~maximum frequency	50.00Hz	★
F8-31	Arbitrary arrival frequency detection amplitude1	0.0%~100.0% (maximum frequency)	0.00%	★
F8-32	Arbitrary arrival frequency detection value 2	0.00Hz~maximum frequency	50.00Hz	★
F8-33	Arbitrary arrival frequency detection amplitude 2	0.0%~100.0% (maximum frequency)	0.00%	★
F8-34	Zero current detection level	0.0%~300.0%	5.00%	★
		100.0% corresponds to the rated motor current		
F8-35	Zero current detection delay time	0.01s~600.00s	0.10s	★
F8-36	Output current exceeds the limit value	0.0% (not tested)	200.00%	★
		0.1%~300.0% (motor rated current)		
F8-37	Output current overrun detection delay time	0.00s~600.00s	0.00s	★
F8-38	Arbitrary arrival current1	0.0%~300.0%(motor rated current)	100.00%	★
F8-39	Arbitrary arrival current 1 amplitude	0.0%~300.0%(motor rated current)	0.00%	★
F8-40	Arbitrary arrival current2	0.0%~300.0%(motor rated current)	100.00%	★
F8-41	Arbitrary arrival current 2 amplitude	0.0%~300.0%(motor rated current)	0.00%	★
F8-42	Timing function selection	0: Invalid 1: Valid	0	★
F8-43	Timed run time selection	0: F8-44 setting	0	★
		1: AI1		
		2: AI2		
		Analog input range corresponds to F8-44		
F8-44	Timed run time	0.0Min~6500.0Min	0.0Min	★
F8-45	AI1 input voltage protection value lower limit	0.00V~F8-46	3.10V	★
F8-46	AI1 input voltage protection value upper limit	F8-45~10.00V	6.80V	★
F8-47	Module temperature reaches	0°C~100°C	90°C	★
F8-48	Cooling fan control	0: Fan running during operation	0	★
		1: The fan keeps running		
F8-49	Wake-up frequency	Dormant frequency (F8-51) ~ Maximum frequency (F0-10)	0.00Hz	★

<b>F8-50</b>	Wake-up delay time	0.0s~6500.0s	<b>0.0s</b>	★
<b>F8-51</b>	Dormancy frequency	0.00Hz~Wakeup frequency (F8-49)	<b>0.00Hz</b>	★
<b>F8-52</b>	Hibernation delay time	0.0s~6500.0s	<b>0.0s</b>	★
<b>F8-53</b>	Arrival time for this run	0.0~6500.0min	<b>0.0Min</b>	★
<b>F8-54</b>	Output power correction factor	0.00%~200.0%	<b>100.00%</b>	★
<b>Group F9 Fault and Protection</b>				
<b>F9-00</b>	Motor overload protection options	0: Forbidden	<b>1</b>	★
		1: Allowed		
<b>F9-01</b>	Motor overload protection gain	0.20~10.00	<b>1</b>	★
<b>F9-02</b>	Motor overload warning factor	50%~100%	<b>80%</b>	★
<b>F9-03</b>	Overvoltage stall gain	0~100	<b>30</b>	★
<b>F9-04</b>	Overvoltage stall protection voltage	650V~800V	<b>720V</b>	★
<b>F9-07</b>	Short circuit to ground protection options	Individual position: power-on to ground short circuit protection selection	<b>1</b>	★
		0: Invalid 1: Valid		
		Ten bits: pre-operation short-circuit protection to ground selection		
		0: Invalid 1: Valid		
<b>F9-08</b>	Brake unit operation starting voltage	650V~800V	<b>720V</b>	★
<b>F9-09</b>	Fault automatic reset times	0~20	<b>0</b>	★
<b>F9-10</b>	Fault DO action selection during automatic fault reset	0: No action	<b>0</b>	★
		1: Action		
<b>F9-11</b>	Fault automatic reset waiting time	0.1s~100.0s	<b>1.0s</b>	★
<b>F9-12</b>	Input phase loss \ contactor suction protection selection	Digit: Input phase loss protection selection	<b>11</b>	★
		Ten bits: contactor suction protection selection		
		0: Prohibited 1: Allowed		
<b>F9-13</b>	Output phase loss protection options	Digit: output phase loss protection selection	<b>11</b>	★
		0: Prohibited 1: Allowed		
		Ten bits: output phase loss protection selection before operation		
		0: Prohibited 1: Allowed		
<b>F9-14</b>	Type of first failure	0: No fault	<b>-</b>	●
		1: Retention		
		2: Accelerated overcurrent		
		3: Deceleration overcurrent		
		4: Constant speed overcurrent		
		5: Accelerated overvoltage		
		6: Deceleration overvoltage		
		7: Constant speed overvoltage		
8: Buffer power failure				

		9: Undervoltage		
		10: Inverter overload		
		11: Motor overload		
		12: Input out of phase		
		13: Output out of phase		
		14: Module overheating		
		15: External failure		
		16: Communication anomaly		
		17: Contactor abnormalities		
		18: Abnormal current detection		
		19: Abnormal motor tuning		
		20: Encoder/PG card abnormality		
		21: Parameter read/write exception		
		22: Inverter hardware abnormalities		
		23: Motor short circuit to ground		
		24: Reserved		
		25: Reserved		
		26: Runtime arrival		
		27: User-defined faults 1		
		28: User-defined fault 2		
		29: Power-up time arrives		
		30: Drop Load		
		31: Loss of PID feedback at runtime		
		40: Fast flow limit timeout		
		41: Switching motors during operation		
		42: Excessive speed deviation		
		43: Motor over speed		
		45: Motor over temperature		
F9-15	Second failure type	51: Initial position error	-	•
F9-16	Third (most recent) failure type	55: Slave failure during master-slave control	-	•
F9-17	Frequency at the third (most recent) failure	-	-	•
F9-18	Current at the third (most recent) fault	-	-	•
F9-19	Busbar voltage at the third (most recent) fault	-	-	•
F9-20	Input terminal status at the third (most recent) fault	-	-	•
F9-21	Output terminal status at the third (most recent) fault	-	-	•
F9-22	Inverter status at the time of the third (most recent) fault	-	-	•

F9-23	Power-up time at the third (most recent) failure	-	-	•
F9-24	Running time at the third (most recent) failure	-	-	•
F9-27	Frequency at second failure	-	-	•
F9-28	Current at second fault	-	-	•
F9-29	Busbar voltage at second fault	-	-	•
F9-30	Input terminal status at second fault	-	-	•
F9-31	Output terminal status at second fault	-	-	•
F9-32	Inverter status at second fault	-	-	•
F9-33	Power-up time at second failure	-	-	•
F9-34	Running time at second failure	-	-	•
F9-37	Frequency at first failure	-	-	•
F9-38	Current at first fault	-	-	•
F9-39	Busbar voltage at first fault	-	-	•
F9-40	Input terminal status at first fault	-	-	•
F9-41	Output terminal status at first fault	-	-	•
F9-42	Inverter status at first failure	-	-	•
F9-43	Power-up time at first failure	-	-	•
F9-44	Running time at first failure	-	-	•
F9-47	Fault protection action option 1	Position: Motor overload	0	★
		0: Free parking		
		1: Shutdown by shutdown		
		2: Continue to run		
		Ten bits: input out of phase		
		Hundred: output out of phase		
		Thousands of bits: external failure		
Wan bit: communication anomaly				
F9-48	Fault protection action option 2	Individual position: encoder/PG card anomaly	0	★
		0: Free parking		
		Ten bits: function code reading and writing abnormalities		
		0: Free parking		
		1: Shutdown by shutdown		
		Hundred bits: inverter overload fault action selection		
		0: Free stop		
		1: Derate operation		
Thousand position: motor overheating				
10,000 bits: running time arrives				
F9-49		Digit: User-defined fault 1	0	★

	Fault protection action option 3	0: Free parking		
		1: Shutdown by shutdown		
		2: Continue to run		
		Ten bits: user-defined fault 2		
		0: Free parking		
		1: Shutdown by shutdown		
		2: Continue to run		
		Hundredth place: power-up time arrives		
		0: Free parking		
		1: Shutdown by shutdown		
		2: Continue to run		
		Thousands of bits: drop load		
		0: Free parking		
		1: Slow down and stop		
		2: Jump directly to 7% of the rated frequency of the motor to continue running without dropping the load		
		Automatic return to set frequency operation		
		10,000 bits: PID feedback lost at runtime		
		0: Free parking		
	1: Shutdown by shutdown			
	2: Continue to run			
<b>F9-50</b>	Fault protection action selection 4	Individual position: excessive speed deviation	<b>0</b>	★
		0: Free parking		
		1: Shutdown by shutdown		
		2: Continue to run		
		Ten bits: motor over speed		
		Hundredth place: initial position error		
<b>F9-54</b>	Continued operation frequency selection in case of failure	0: Run at the current operating frequency	<b>0</b>	★
		1: Running at set frequency		
		2: Operating at the upper limit frequency		
		3: Run at the lower frequency limit		
		4: Runs on abnormal standby frequency		
<b>F9-55</b>	Abnormal standby frequency	0.0%~100.0%	<b>100.00%</b>	★
		(100.0% corresponds to the maximum frequency F0-10)		
<b>F9-56</b>	Motor temperature sensor type	0: No temperature sensor	<b>0</b>	★
		1: PT100		
		2: PT1000		
<b>F9-57</b>	Motor overheating protection threshold	0°C~200°C	<b>110°C</b>	★

F9-58	Motor overheating pre-alarm threshold	0°C~200°C	90°C	★
F9-59	Instant stop non-stop function selection	0 Invalid	0	★
		1 Bus voltage constant control		
		2 Deceleration stop		
F9-60	Instantaneous stop and non-stop recovery voltage	80%~100%	85%	★
F9-61	Instantaneous stop and non-stop voltage recovery judgment time	0.0~100.0s	0.5S	★
F9-62	Instantaneous stop and non-stop action voltage	60%~100%	80%	★
F9-63	Drop protection options	0: Invalid	0	★
		1: Effective		
F9-64	Drop detection level	0.0~100.0%	10.00%	★
F9-65	Drop detection time	0.0~60.0s	1.0s	★
F9-67	Overspeed detection value	0.0%~50.0% (maximum frequency)	20.00%	★
F9-68	Over speed detection time	0.0s: no detection	1.0s	★
		0.1~60.0s		
F9-69	Excessive speed deviation detection value	0.0%~50.0% (maximum frequency)	20.00%	★
F9-70	Detection time for excessive speed deviation	0.0s: no detection	5.0s	★
		0.1~60.0s		
F9-71	Instant stop non-stop gain Kp	0~100	40	★
F9-72	Instantaneous stop non-stop integration factor Ki	0~100	30	★
F9-73	Instant stop non-stop action deceleration time	0~300.0s	20.0s	★
<b>FA group PID function</b>				
FA-00	PID given source	0: FA-01 setting	0	★
		1: AI1		
		2: AI2		
		3: Panel Potentiometer		
		4: Pulse setting (X6)		
		5: Communication given		
FA-01	PID value is given	0.0%~100.0%	50.00%	★
		6: Multi-segment command giving		
FA-02	PID feedback source	0: AI1	0	★
		1: AI2		
		2: Panel Potentiometer		
		3: AI1-AI2		
		4: Pulse setting (X6)		
		5: Communication given		
6: AI1+AI2				

		7: MAX( AI1 , AI2 )		
		8: MIN( AI1 , AI2 )		
FA-03	Direction of PID action	0: positive effect	0	★
		1: Counterproductive		
FA-04	PID giving feedback range	0~65535	1000	★
FA-05	Proportional gain KP1	0.0~1000.0	20	★
FA-06	Integration time TI1	0.01s~10.00s	2.00s	★
FA-07	Differential Time TD1	0.000s~10.000s	0.000s	★
FA-08	PID reversal cut-off frequency	0.00~maximum frequency	0.00Hz	★
FA-09	PID deviation limit	0.0%~100.0%	0.00%	★
FA-10	PID differential limiting	0.00%~100.00%	0.10%	★
FA-11	PID given change time	0.00~650.00s	0.00s	★
FA-12	PID feedback filtering time	0.00~60.00s	0.00s	★
FA-13	PID output filtering time	0.00~60.00s	0.00s	★
FA-14	Reserved	-	-	★
FA-15	Proportional gain KP2	0.0~1000.0	20	★
FA-16	Integration time TI2	0.01s~10.00s	2.00s	★
FA-17	Differential Time TD2	0.000s~10.000s	0.000s	★
FA-18	PID parameter switching conditions	0: No switching	0	★
		1: Switching via X terminal		
		2: Automatic switching according to deviation		
		3: Automatic switching according to operating frequency		
FA-19	PID parameter switching deviation 1	0.0%~FA-20	20.00%	★
FA-20	PID parameter switching deviation 2	FA-19~100.0%	80.00%	★
FA-21	PID initial value	0.0%~100.0%	0.00%	★
FA-22	PID initial value hold time	0.00~650.00s	0.00s	★
FA-23	Reserved	-	-	-
FA-24	Reserved	-	-	-
FA-25	PID integral properties	Individuals: Integral separation	0	★
		0: Invalid		
		1: Effective		
		Ten bits: whether to stop integration after the output reaches the limit value		
		0: Continue points		
		1: Stop points		
FA-26	PID feedback loss detection value	0.0%: No judgment of feedback loss	0.00%	★
		0.1%~100.0%		
FA-27	PID feedback loss detection time	0.0s~20.0s	0.0s	★
FA-28	PID stop operation	0: Stop without calculation	0	★

		1: Arithmetic during downtime		
<b>FB group fixing length and counting</b>				
<b>FB-05</b>	Set length	0m~65535m	<b>1000m</b>	★
<b>FB-06</b>	Actual length	0m~65535m	<b>0m</b>	★
<b>FB-07</b>	Number of pulses per meter	0.1~6553.5	<b>100</b>	★
<b>FB-08</b>	Set count value	1~65535	<b>1000</b>	★
<b>FB-09</b>	Specify the count value	1~65535	<b>1000</b>	★
<b>FC group Multi-segment instruction, simple PLC</b>				
<b>FC-00</b>	Multi-band frequency 0	-100.0%~100.0%	<b>0.00%</b>	★
<b>FC-01</b>	Multi-band frequency1	-100.0%~100.0%	<b>0.00%</b>	★
<b>FC-02</b>	Multi-band frequency2	-100.0%~100.0%	<b>0.00%</b>	★
<b>FC-03</b>	Multi-band frequency3	-100.0%~100.0%	<b>0.00%</b>	★
<b>FC-04</b>	Multi-band frequency4	-100.0%~100.0%	<b>0.00%</b>	★
<b>FC-05</b>	Multi-band frequency5	-100.0%~100.0%	<b>0.00%</b>	★
<b>FC-06</b>	Multi-band frequency6	-100.0%~100.0%	<b>0.00%</b>	★
<b>FC-07</b>	Multi-band frequency7	-100.0%~100.0%	<b>0.00%</b>	★
<b>FC-08</b>	Multi-band frequency8	-100.0%~100.0%	<b>0.00%</b>	★
<b>FC-09</b>	Multi-band frequency9	-100.0%~100.0%	<b>0.00%</b>	★
<b>FC-10</b>	Multi-band frequency 10	-100.0%~100.0%	<b>0.00%</b>	★
<b>FC-11</b>	Multi-band frequency 11	-100.0%~100.0%	<b>0.00%</b>	★
<b>FC-12</b>	Multi-band frequency 12	-100.0%~100.0%	<b>0.00%</b>	★
<b>FC-13</b>	Multi-band frequency 13	-100.0%~100.0%	<b>0.00%</b>	★
<b>FC-14</b>	Multi-band frequency 14	-100.0%~100.0%	<b>0.00%</b>	★
<b>FC-15</b>	Multi-band frequency 15	-100.0%~100.0%	<b>0.00%</b>	★
<b>FC-16</b>	Simple PLC operation method	0: Single run end stop	<b>0</b>	★
		1: Single run end hold final value		
		2: Keep cycling		
<b>FC-17</b>	Simple PLC power-down memory selection	Digit: Power-down memory selection	<b>0</b>	★
		0: Power down without memory		
		Ten positions: downtime memory selection		
		0: Shutdown without memory		
		1: Power-down memory		
1: Downtime memory				
<b>FC-18</b>	Simple PLC segment 0 runtime	0.0s(h)~6553.5s(h)	<b>0.0s(h)</b>	★
<b>FC-19</b>	Simple PLC section 0 acceleration and deceleration time selection	0~3	<b>0</b>	★
<b>FC-20</b>	Simple PLC 1st period run time	0.0s(h)~6553.5s(h)	<b>0.0s(h)</b>	★



<b>FC-21</b>	Simple PLC 1st stage acceleration and deceleration time selection	0~3	<b>0</b>	★
<b>FC-22</b>	Simple PLC 2nd runtime	0.0s(h)~6553.5s(h)	<b>0.0s(h)</b>	★
<b>FC-23</b>	Simple PLC 2nd stage acceleration and deceleration time selection	0~3	<b>0</b>	★
<b>FC-24</b>	Simple PLC Section 3 runtime	0.0s(h)~6553.5s(h)	<b>0.0s(h)</b>	★
<b>FC-25</b>	Simple PLC section 3 acceleration and deceleration time selection	0~3	<b>0</b>	★
<b>FC-26</b>	Simple PLC segment 4 runtime	0.0s(h)~6553.5s(h)	<b>0.0s(h)</b>	★
<b>FC-27</b>	Simple PLC paragraph 4 acceleration and deceleration time selection	0~3	<b>0</b>	★
<b>FC-28</b>	Simple PLC Section 5 runtime	0.0s(h)~6553.5s(h)	<b>0.0s(h)</b>	★
<b>FC-29</b>	Simple PLC section 5 acceleration and deceleration time selection	0~3	<b>0</b>	★
<b>FC-30</b>	Simple PLC paragraph 6 runtime	0.0s(h)~6553.5s(h)	<b>0.0s(h)</b>	★
<b>FC-31</b>	Simple PLC section 6 acceleration and deceleration time selection	0~3	<b>0</b>	★
<b>FC-32</b>	Simple PLC paragraph 7 runtime	0.0s(h)~6553.5s(h)	<b>0.0s(h)</b>	★
<b>FC-33</b>	Simple PLC paragraph 7 acceleration and deceleration time selection	0~3	<b>0</b>	★
<b>FC-34</b>	Simple PLC paragraph 8 runtime	0.0s(h)~6553.5s(h)	<b>0.0s(h)</b>	★
<b>FC-35</b>	Simple PLC section 8 acceleration and deceleration time selection	0~3	<b>0</b>	★
<b>FC-36</b>	Simple PLC paragraph 9 runtime	0.0s(h)~6553.5s(h)	<b>0.0s(h)</b>	★
<b>FC-37</b>	Simple PLC paragraph 9 acceleration and deceleration time selection	0~3	<b>0</b>	★
<b>FC-38</b>	Simple PLC paragraph 10 runtime	0.0s(h)~6553.5s(h)	<b>0.0s(h)</b>	★
<b>FC-39</b>	Simple PLC 10th acceleration and deceleration time selection	0~3	<b>0</b>	★
<b>FC-40</b>	Simple PLC paragraph 11 runtime	0.0s(h)~6553.5s(h)	<b>0.0s(h)</b>	★
<b>FC-41</b>	Simple PLC paragraph 11 acceleration and deceleration time selection	0~3	<b>0</b>	★
<b>FC-42</b>	Simple PLC 12th runtime	0.0s(h)~6553.5s(h)	<b>0.0s(h)</b>	★
<b>FC-43</b>	Simple PLC section 12 acceleration and deceleration time selection	0~3	<b>0</b>	★
<b>FC-44</b>	Simple PLC paragraph 13 runtime	0.0s(h)~6553.5s(h)	<b>0.0s(h)</b>	★
<b>FC-45</b>	Simple PLC paragraph 13 acceleration and deceleration time selection	0~3	<b>0</b>	★
<b>FC-46</b>	Simple PLC paragraph 14 runtime	0.0s(h)~6553.5s(h)	<b>0.0s(h)</b>	★
<b>FC-47</b>	Simple PLC paragraph 14 acceleration and deceleration time selection	0~3	<b>0</b>	★

<b>FC-48</b>	Simple PLC paragraph 15 running time	0.0s(h)~6553.5s(h)	<b>0.0s(h)</b>	★
<b>FC-49</b>	Simple PLC paragraph 15 acceleration and deceleration time selection	0~3	<b>0</b>	★
<b>FC-50</b>	Simple PLC runtime units	0: s (seconds) 1: h (hour)	<b>0</b>	★
<b>FC-51</b>	Multi-segment instruction 0 giving method	0: Function code FC-00 is given 1: AI1 2: AI2 3: Panel Potentiometer 4: Pulse 5: PID 6: Preset frequency (F0-08) is given, UP/DOWN can be modified	<b>0</b>	★
<b>Group Fd Communication parameters</b>				
<b>Fd-00</b>	Communication baud rate	Digit: MODBUS 0: 300BPS 1: 600BPS 2: 1200BPS 3: 2400BPS 4: 4800BPS 5: 9600BPS 6: 19200BPS 7: 38400BPS 8: 57600BPS 9: 115200BPS Tenth position: reserved Hundredth place: Reserved Thousands: Reserved	<b>5</b>	★
<b>Fd-01</b>	MODBUS Data Format	0: No checksum (8-N-2) 1: Even check (8-E-1) 2: Odd check (8-O-1) 3: No checksum (8-N-1)	<b>0</b>	★
<b>Fd-02</b>	Local Address	0: Broadcast address 1~247	<b>1</b>	★
<b>Fd-03</b>	MODBUS answer delay	0~20ms	<b>2</b>	★
<b>Fd-04</b>	Serial communication timeout time	0.0: Invalid 0.1~60.0s	<b>0</b>	★
<b>Fd-05</b>	Communication data format	Digit: MODBUS	<b>30</b>	★

		0: Non-standard MODBUS protocol		
		1: Standard MODBUS protocol		
<b>Fd-06</b>	Communication reading current resolution	0: 0.01A (valid for ≤55kW)	<b>0</b>	★
		1: 0.1A		
<b>FP Group Function Code Management</b>				
<b>FP-00</b>	User Password	0-65535	<b>0</b>	★
<b>FP-01</b>	Parameter initialization	0: No operation	<b>0</b>	★
		01: Restore factory parameters, not including motor parameters		
		02: Clear the recorded information		
		04: Backup the user's current parameters		
		501: Restore user backup parameters		
<b>FP-02</b>	Function parameter group display selection	Digit: U group display selection	<b>11</b>	★
		0: No display		
		1: Display		
		Ten bits: P group display selection		
		0: No display		
		1: Display		
<b>FP-03</b>	Personalized parameter group display selection	Digit: User-defined parameter group display selection	<b>0</b>	★
		0: No display		
		1: Display		
		Ten bits: user change parameter group display selection		
		0: No display		
		1: Display		
<b>FP-04</b>	Function Code Modification Properties	0: Modifiable	<b>0</b>	★
		1: Not modifiable		
<b>P0 group torque control parameters</b>				
<b>P0-00</b>	Speed/Torque Control Method Selection	0: Speed control	<b>0</b>	★
		1: Torque control		
<b>P0-01</b>	Torque setting selection in torque control mode	0: Digital setting 1 (P0-03)	<b>0</b>	★
		1: AI1		
		2: AI2		
		3: Panel Potentiometer		
		4: PULSE pulse		
		5: Communication given		
		6: MIN(AI1,AI2)		
		7: MAX(AI1,AI2)		
		(Full range for options 1-7, corresponding to P0-03 digital settings)		

P0-03	Digital setting of torque in torque control mode	-200.0%~200.0%	150.00%	★
P0-05	Torque control forward maximum frequency	0.00Hz~maximum frequency	50.00Hz	★
P0-06	Torque control reverse maximum frequency	0.00Hz~maximum frequency	50.00Hz	★
P0-07	Torque rise filtering time	0.00s~65000s	0.00s	★
P0-08	Torque drop filtering time	0.00s~65000s	0.00s	★
<b>P5 group Control optimization parameters</b>				
P5-00	DPWM switching upper frequency	5.00Hz~maximum frequency	8.00Hz	★
P5-01	PWM modulation method	0: Asynchronous modulation 1: Synchronous modulation	0	★
P5-02	Deadband compensation mode selection	0: No compensation 1: Compensation mode 1	1	★
P5-03	Random PWM depth	0: Random PWM is invalid 1~10: PWM carrier frequency random depth	0	★
P5-04	Fast current limit enable	0: No enablement 1: Enabling	1	★
P5-05	Maximum output voltage factor	100~110%	105%	★
P5-06	Undervoltage point setting	210~420V	350V	★
P5-08	Low-speed carrier frequency	0.0~8.0kHz	0	★
P5-09	Overpressure point setting	200.0V~2500.0V	Model	★
P5-11	Low-speed DC braking threshold	0.00~5.00Hz	0.30Hz	★
<b>Group U0 Basic monitoring parameters</b>				
U0-00	Operating frequency (Hz)	0.01Hz	7000H	
U0-01	Setting frequency (Hz)	0.01Hz	7001H	
U0-02	Bus voltage (V)	0.1V	7002H	
U0-03	Output Voltage (V)	1V	7003H	
U0-04	Output current (A)	0.01A	7004H	
U0-05	Output power (kW)	0.1kW	7005H	
U0-06	Output torque (%)	0.001	7006H	
U0-07	X input state	1	7007H	
U0-08	DO Output Status	1	7008H	
U0-09	AI1 Voltage (V)	0.01V	7009H	
U0-10	AI2 Voltage (V) / Current (mA)	0.01V/0.01mA	700AH	
U0-12	Counting value	1	700CH	
U0-13	Length value	1	700DH	
U0-14	Load speed display	1	700EH	
U0-15	PID setting	1	700FH	
U0-16	PID feedback	1	7010H	

U0-17	PLC Phase	1	7011H
U0-18	Input pulse frequency (Hz)	0.01kHz	7012H
U0-19	Feedback speed (Hz)	0.01Hz	7013H
U0-20	Remaining running time	0.1Min	7014H
U0-21	AI1 Pre-calibration voltage	0.001V	7015H
U0-22	AI2 Pre-calibration voltage (V) / current (mA)	0.001V/0.01mA	7016H
U0-24	Line Speed	1m/Min	7018H
U0-25	Current power-up time	1Min	7019H
U0-26	Current running time	0.1Min	701AH
U0-27	Input pulse frequency	1Hz	701BH
U0-28	Communication setpoint	0.0001	701CH
U0-30	Main frequency display	0.01Hz	701EH
U0-31	Auxiliary frequency display	0.01Hz	701FH
U0-32	View any memory address value	1	7020H
U0-34	Motor temperature value	1°C	7022H
U0-39	V/F separation target voltage	1V	7027H
U0-40	V/F Separate Output Voltage	1V	7028H
U0-41	X Visual display of input status	1.00	7029H
U0-42	Visual display of DO output status	1.00	702AH
U0-43	X Function Status Visual Display 1 (Function 01-40)	1.00	702BH
U0-44	X Function Status Visual Display 2 (Function 41-80)	1.00	702CH
U0-45	Fault Information	1.00	702DH
U0-59	Setting frequency (%)	0.00	703BH
U0-60	Operating frequency (%)	0.00	703CH
U0-61	Inverter status	1.00	703DH
U0-62	Current fault code	1.00	703EH

## Chapter 7 Troubleshooting and abnormal treatment



**Danger**

- 1、 It is strictly forbidden to conduct wiring or overhaul when the power is on, otherwise there is a risk of electric shock.
- 2、 Do not disassemble the casing or touch the internal circuit after the inverter is charged, otherwise there will be a risk of electric shock.
- 3、 fault checking must be carried out by professionals, non-professional personnel are strictly prohibited to check, maintain and repair the inverter.

## 7.1 Cause of failure and its countermeasures

When a fault occurs, please first carefully troubleshoot according to the following table, and when the fault cannot be eliminated, do not power up by yourself. Please contact the supplier or manufacturer for technical support in time.

You can view the previous two, previous and latest fault record types by function codes F9-14, F9-15 and F9-16. The fault types are recorded as numeric codes (1-75), and the fault codes correspond to the fault display and fault names and suggested solutions as shown in the table below.

## 7.2 Common Troubleshooting

Fault Code	Fault display	Fault name	Cause	Policy
02	Er02	Accelerated overcurrent	Torque boost value is too large for V/f control	Decrease torque boost value
			Too much starting frequency	Lower starting frequency value
			Acceleration time is too short	Extended acceleration time
			Improper setting of motor parameters	Correct setting according to motor nameplate
			Overload	Load reduction
			Inappropriate V/f curve for V/f control	Set the V/f curve correctly
			Restarting of rotating motors	Reduced current limit or speed search start
03	Er03	Deceleration overcurrent	Too much inertia of the load	Use of energy brakes
			Deceleration time is too short	Extended deceleration time
			Low grid input voltage	Check grid voltage
			Output phase to phase short circuit or short circuit to ground	Check motor wiring and output to ground impedance
04	Er04	Constant speed overcurrent	Overload	Load reduction
			Inverter power level is too small	Selecting the right inverter power
			Low grid input voltage	Check grid voltage
05	Er05	Accelerated overpressure	Output phase to phase short circuit or short circuit to ground	Check motor wiring and output to ground impedance
			Too much inertia of the load	Use of energy brakes
			Abnormal input voltage	Check grid voltage
06	Er06		Output phase to phase short circuit or short circuit to ground	Check motor wiring and output to ground impedance
			Too much inertia of the load	Use of energy brakes

		Deceleration overpressure	Deceleration time is too short	Extended deceleration time
			Abnormal input voltage	Check grid voltage
			Improper setting of regulator parameters during vector control operation	Correct setting of regulator parameters
			Output phase to phase short circuit or short circuit to ground	Check motor wiring and output to ground impedance
07	Er07	Constant speed overpressure	Improper setting of regulator parameters during vector control operation	Correct setting of regulator parameters
			Abnormal input voltage	Check grid voltage
			Too much load fluctuation	Check the load
			Output phase to phase short circuit or short circuit to ground	Check motor wiring and output to ground impedance
08	Er08	Input power abnormal	Severe three-phase unbalance of input power supply voltage	Check input grid voltage
			Abnormal power input wiring	Check power input wiring
			Abnormal DC bus capacitance	Seeking Services
09	Er09	Abnormal power supply during operation	DC bus voltage fluctuates too much or drops out during operation	Check whether the input grid voltage and load are normal
10	Er10	Drive overload	Torque boost value is too large for V/f control	Decrease torque boost value
			Too much starting frequency	Lower starting frequency value
			Acceleration and deceleration times are too short	Extended acceleration and deceleration time
			Improper setting of motor parameters	Correct setting according to motor nameplate
			Overload	Load reduction
			Inappropriate V/f curve for V/f control	Set the V/f curve correctly
			Restarting of rotating motors	Reduced current limit or speed search start
Output phase to phase short circuit or short circuit to ground	Check motor wiring and output to ground impedance			
11	Er11	Motor overload	Torque boost value is too large for V/f control	Decrease torque boost value
			Inappropriate V/f curve for V/f control	Set the V/f curve correctly
			Improper setting of motor parameters	Correct setting according to motor nameplate
			Improper setting of motor overload protection time	Correctly set the motor overload protection time
			Motor blockage or sudden load change is too large	Check the cause of motor blockage or check the load condition
			Long-term low speed and heavy load operation of general motors	Selecting inverter motors
12	Er12	Input out of phase	Abnormal three-phase input voltage	Check peripheral circuit problems
			Driver board abnormality	Seeking Services
			Lightning protection board anomaly	Seeking Services
			Main control board abnormal	Seeking Services
13	Er13	Output out of phase	Abnormal motor wire connection	Check the motor connection
			Motor three-phase unbalance	Check the motor or replace it
			Incorrect setting of vector control parameters	Correct setting of vector control parameters

14	Er14	Heat sink overheat protection	Fan damage	Fan replacement
			Blocked air ducts	Unclogging of air ducts
			Temperature sensor abnormality	Seeking Services
			Inverter module installation abnormality	Seeking Services
15	Er15	External equipment failure	External fault terminal active	Check the status of the external fault terminal
			Stall condition lasts too long	Check for load abnormalities
16	Er16	Port communication exception	Improper baud rate setting for communication	Correct setting
			Communication port connection cable disconnected	Reconnect
			The upper unit is not working	Make the upper computer work
			Frequency converter itself communication parameter error	Correct setting
17	Er17	Contactor abnormality	Contactor contact resistance is too high	Check if the contactor is damaged
			Contactor is not engaged	Replace the contactor and check the circuit
18	Er18	Abnormal current detection circuit	Abnormal connection between control board and driver board	Check the lineup and reinsert
			Control board current detection circuit abnormal	Seeking Services
			Driver board current detection circuit abnormal	Seeking Services
			Damaged current sensor	Seeking Services
			Switching power supply damage	Seeking Services
19	Er19	Parameter recognition failure	Bad motor wiring	Check motor wiring
			Identify when the motor is rotating	Identify when the motor is at standstill
			The deviation of motor parameter setting is too large	Correct setting according to motor nameplate
21	Er21	EEPROM read/write failure	An abnormality occurred in the parameter reading and writing on the control board	Seeking Services
22	Er22	Hardware Anomaly 1	Overcurrent factors	Handled in accordance with overcurrent treatment
			Input power abnormal	Check input grid voltage
			Abnormal motor output	Check motor or motor wiring
			Inverter module abnormal	Seeking Services
23	Er23	Output shorted to ground	Output wiring shorted to ground	Check motor wiring and output to ground impedance
			Abnormal motor insulation	Check the motor
			Inverter module abnormal	Seeking Services
			Output leakage current to ground is too high	Seeking Services
26	Er26	Continuous run time to	Continuous run time arrival function is set	See F8 group function description
29	Er29	Cumulative running time to	Cumulative runtime arrival function is set	See F8 group function description
30	Er30	Load Drop Failure	Inverter operating current less than 9-64 setpoint	Correctly set 9-64 dropout level
31	Er31	PID feedback lost	PID feedback channel abnormality	Check the feedback channel
			PID parameter setting is not reasonable	Correct setting
40	Er40	Wave-by-wave current limiting fault	Excessive load during operation	Check the load for short circuit, blocked rotation



41	Er41	Motor switching failure	Switching motors during operation	Motor switching operation after stopping the machine
42	Er42	Speed deviation fault	No parameter identification	Perform parameter identification
			Speed deviation is too large, 9-69,9-70 parameters are not reasonable	Correctly set parameters
			Encoder parameter setting error	Reasonable setting parameters
43	ER43	Over speed fault	No parameter identification	Perform parameter identification
			Speed deviation is too large, 9-67,9-68 parameters are not reasonable	Correctly set parameters
			Encoder parameter setting error	Reasonable setting parameters
45	Er45	Excessive temperature	Temperature sampling failure	Check the temperature sampling link

## Chapter 8 Maintenance and Care

	<b>Danger</b>
1	Before carrying out maintenance or repair, please cut off all the equipment power, after cutting off the inverter input power, because there is still residual voltage on the internal DC capacitor of the inverter, please wait at least a few minutes for the power indicator to go out before operation, and when the power is on again, you need to wait for the interval of power on time specified by the inverter.
2	Do not remove the inverter housing, change the wiring, remove the cable or replace the cooling fan while the inverter is in operation, otherwise there is a risk of electric shock.
3	please be sure to ground the grounding terminal of the motor, otherwise there is a risk of electric shock in contact with the motor shell.
4	Do not perform maintenance, servicing and repair if you are not a professional electrician.

	<b>Attention</b>
1	If you need to replace the fan, please correctly identify the direction of the fan outlet, if the wrong direction, it will lead to cold but is ineffective and does not provide cooling.
2	Do not disassemble and install the motor when the inverter is running. Otherwise it will cause electric shock and inverter damage.
3	When wiring the control circuit, please use shielded cable and reliable grounding.
4	Do not change the internal circuit of the inverter, otherwise it will cause damage to the inverter.

### 8.1 Daily inspection items

Users should carry out routine and regular maintenance and repair of the inverter to avoid abnormal aging of the internal components of the inverter due to the influence of temperature, humidity, dust and vibration of the environment, which may lead to an increase in the probability of potential failure of the inverter or reduce the service life of the inverter. Especially for high temperature environment, frequent starting and stopping occasions, power and load fluctuation conditions, the existence of large vibration or shock environment, the existence of dust / hydrochloric acid corrosive environment should be shortened as appropriate periodic inspection cycle interval.

To ensure that the inverter functions properly and the product is protected from damage, please check the following items daily.

Inspection items	Inspection content	Countermeasures in case of failure
Motor	Whether the motor has abnormal sound and vibration phenomenon	<ul style="list-style-type: none"> <li>● Confirmation of abnormal mechanical connections.</li> <li>● Confirm that the motor is out of phase.</li> <li>● Confirm that the motor fixing screws are secure.</li> </ul>
Fans	Abnormal use of inverter and motor cooling fan	<ul style="list-style-type: none"> <li>● Confirm that the inverter cooling fan is operating.</li> <li>● Confirmation of abnormalities in the motor-side cooling fan.</li> <li>● Confirm that ventilation channels are not blocked.</li> <li>● Confirm that the ambient temperature is within the allowable range.</li> </ul>
Installation Environment	Is the electrical cabinet and cable trough abnormal	<ul style="list-style-type: none"> <li>● Confirm that there is no insulation breakage in the incoming and outgoing cables of the inverter.</li> <li>● Confirm that the connection cable terminals are not loose or corroded through.</li> </ul>
Load	Does the inverter operating current exceed the inverter rating and motor rating for a certain period of time	<ul style="list-style-type: none"> <li>● Confirm that the motor parameters are set correctly.</li> <li>● Confirm that the motor is not overloaded.</li> <li>● Check if the mechanical vibration is too large (normal condition &lt;1g).</li> </ul>
Input Voltage	Is the power supply voltage between the main circuit and the control circuit abnormal	<ul style="list-style-type: none"> <li>● Confirmation that the input voltage is within the allowable range.</li> <li>● Confirm that there is no large load starting around.</li> </ul>

## 8.2 Periodic inspection items

Please regularly check the places that are difficult to check in operation. You should always keep the inverter in a clean state, effectively remove the dust on the upper surface of the inverter, prevent the dust from entering the interior of the inverter, especially the metal dust, and effectively remove the oil from the cooling fan of the inverter.

Inspection items	Inspection content	Inspection content
Complete machine	Whether there is garbage, dirt, dust accumulation on the surface	<ul style="list-style-type: none"> <li>● Confirm that the inverter cabinet is powered off.</li> <li>● Removal of trash or dust by vacuuming to avoid contact with components.</li> </ul> <p>If surface dirt cannot be removed, wipe with alcohol and allow to dry and evaporate completely.</p>

Wires and Cables	Whether the power cord and connections are discolored.	● Replacement of cables that have cracked.
	Whether the insulation layer is aging or cracked.	● Replace the connection terminal that has been damaged.
Electromagnetic contactor periphery	Whether the action is not firmly sucked or make a strange noise.	● Replace the components that have been abnormal.
	Whether there is a short circuit, water contamination, expansion, rupture of peripheral devices	
Duct Vents	Whether the air duct and heat sink are blocked.	● Sweeping of air ducts.
	Whether the fan is damaged.	● Replace the fan.
Control circuit	Whether the control components have poor contact.	● Cleaning of foreign matter on the surface of control circuits and connection terminals.
	Terminals Whether the screws are loose.	
	Control the cable for insulation cracking.	● Replace broken and corroded control cables.

### 8.3 Inverter storage

Frequency converter temporary storage and long-term storage must pay attention to the following points.

(1) Store as much as possible in the original packaging in our boxes.

(2) Do not allow the whole machine to be placed in humid, high temperature, or outdoor exposure for a long time.

(3) Long time storage will lead to the deterioration of electrolytic capacitors, must ensure that the power is turned on once within 6 months, the power-on time is at least 5 hours, the input voltage must be slowly increased to the rated value with the regulator or consult the technical support of inverter professionals.

# Appendix A Modbus Communication Protocol

CT10M series inverter provides RS485 communication interface and supports Modbus-RTU slave communication protocol. Users can connect the inverter to the "single master and multiple slave" PC/PLC control network with RS485 bus, and the inverter can be used as a slave to realize centralized control through the PC/PLC host. Through the Modbus communication protocol, you can set the operation command of the inverter, modify or read the function code parameters, read the working status and fault information of the inverter, etc.

This serial communication protocol defines the content of the information transmitted in serial communication and the format used. It includes the host polling (or broadcast) format, the encoding method of the host, the content including the function code of the requested action, the transmitted data and the error checks, etc. The response from the slave uses the same structure, and the content includes action confirmation, return data and error checks, etc. If the slave makes an error in receiving information or fails to complete the action requested by the host, it will organize a fault message as a response back to the host.

## 1、 Bus structure

### 1) Topology

Single-Master-Multi-Slave System. Each communication device in the network has a unique slave address. One of the devices acts as the communication host (often a PC host, PLC, HMI, etc.), initiates communication, reads or writes parameters to the slave, and the slave responds to the host's queries or communication operations to this machine. Only one device can send data at the same moment, while the other devices are in the receiving state.

The slave addresses are set in the range of 1 to 247, with 0 being the broadcast communication address. All slave addresses in the network must be unique.

### 2) Communication transmission method

Asynchronous serial, half-duplex transmission method. Data is sent one frame at a time in the form of a telegram during serial asynchronous communication. It is agreed in the MODBUS-RTU protocol that when the idle time without data on the communication data line is greater than 3.5 Byte of transmission time, it indicates the start of a new communication frame.

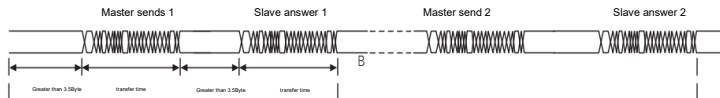

The built-in communication protocol of CT10M series inverter is Modbus-RTU slave communication protocol, which can respond to the "query/command" of the host, or make corresponding action according to the "query/command" of the host, and communicate data response. The host can communicate to a slave individually or broadcast information to all slaves. For the individual access "query/command" from the host, the accessed slave has to return an answer frame; for the broadcast message from the host, the slave does not need to respond back to the host.

## 2、Communication data format

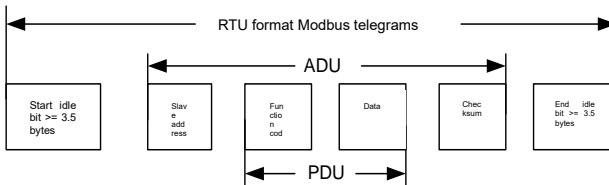

Attachment 1, RTU data frame format

RTU method.

The idle time between frames in the RTU mode can be set either by function code or by adhering to the Modbus internal convention, which has the following minimum idle time between frames.

- frames are defined by bus idle time greater than or equal to 3.5 bytes of time at the head and tail of the frame.
- the gap between characters must be less than 1.5 characters communication time after the start of the frame, otherwise the newly received characters will be treated as the header of a new frame.
- The data checksum uses CRC-16, the whole message is involved in the checksum, and the high and low bytes of the checksum need to be exchanged and sent. Please refer to the example at the back of the protocol for the specific CRC checksum.

### Data frame field description.

Frame header START	Greater than 3.5 character transfer time idle
Slave Address ADR	Communication address range: 1 to 247; 0: broadcast address
Command Code CMD	03: Read slave parameters; 06: Write slave parameters
Function code address H	The internal parameter address of the inverter is expressed in hexadecimal system; it is divided into function code type and non-function code type (such as operation status parameter, operation command, etc.) parameters, etc. See the address definition for details.
Function code address L	When transmitting, the high byte comes first and the low byte comes second.
Data H	The data to be answered, or the data to be written, is transmitted with the high byte first and the low byte second.
Data L	
CRC CHK low	Detection value: CRC16 checksum value. When transmitting, the low byte comes first and the high byte comes second.
CRC CHK High	See the description of CRC checksum in this section for details on the calculation method.
END	At 3.5 characters

## Function 0x03 Read multiple inverter function code parameters and status words

PDU section content	Data length (bytes)	Scope
Request.		
Function Code	1	0x03
Register start address	2	0x0000 ~ 0xFFFF
Number of registers	2	0x0001 ~ 0x0010
Response.		
Function Code	1	0x03
Number of bytes read	1	2*Number of registers
Read Content	2*Number of registers	

## Function code 0x06 Rewrite function code or control parameter

PDU section content	Data length (bytes)	Scope
Request.		
Function Code	1	0x06
Register Address	2	0x0000 ~ 0xFFFF
Register Data	2	0x0000 ~ 0xFFFF
Response.		
Function Code	1	0x06
Register Address	2	0x0000 ~ 0xFFFF
Register Data	2	0x0000 ~ 0xFFFF

CT10M series inverter supports Modbus-RTU communication protocol. Through these protocols, the host computer can control, monitor and modify the function parameters of the inverter.

CT10M communication data can be divided into function code data and non-function code data. Non-function code data includes operation command, operation status, operation parameters, fault information, etc.

### 3. Function code data address definition

The function code data is an important setting parameter of the inverter, divided into Group F and Group A function parameters, as follows.

Function code data	Group F (read/write)	f0, f1, f2, f3, f4, f5, f6, f7, f8, f9, fa, fc, fd, fe, ff
	P group (read/write)	P0, P5

#### 3.1 Parameter address definition during function code reading.

For F0 ~ FF, P0 ~ PF group function code data, its communication address high sixteen bits directly for the function group number, low sixteen bits directly for the function code in the function group serial number, for example, as follows.

FA-17 function parameter, whose communication address is **FA11H**, where FAH represents the FA group function parameter, 11H represents the function code in the function group serial number 17 in hexadecimal data format

P5-08 functional parameters, whose communication address is **A508H**, where A5H represents the P5 group functional parameters, 08H represents the function code in the function group serial number 8 in hexadecimal data format

### 3.2 Address definition when function code parameters are written.

For frequent EEPROM writes, which can lead to a reduction in the life of the EEPROM device, the inverter differentiates the function code parameter group codes according to the function code preservation needs.

For the F0-FF group function code data, the high sixteen bits of the communication address are distinguished as 00-0F or F0-FF according to whether they are written to EEPROM or not, and the low sixteen bits are directly the function code serial number in the function group, for example, as follows.

--Write function parameters F0-18.

The communication address is **0012H when** no EEPROM writing is required.

The communication address is **F012H when the** EEPROM needs to be written.

For P0 to PF group function code data, the high sixteen bits of its communication address are distinguished as 40 to 4F or A0 to AF according to whether it needs to be written into EEPROM, and the low sixteen bits are directly the function code serial number in the function group, for example, as follows.

--Write functional parameters AC-11.

The communication address is **4C0BH when** no EEPROM writing is required.

The communication address is **AC0BH when the** EEPROM needs to be written.

Note: For the pump industry, the FP parameter group is directly mapped to the P9 parameter group, so the access address and read address are the same as the P9 parameter group. If reading FP-00 parameters, the communication access address is **A900H when** reading, when writing parameters, the communication address is **4900H when** not writing to EEPROM, and the address is **A900H** when writing to EEPROM.

## 4、Status parameter reading and control parameter writing

Non-functional code data	Status data (read-only)	U group monitoring parameters, inverter fault description, inverter operation status
	Control parameters (write only)	Control commands, control parameters, parameter initialization, etc.

### 4.1) Status data reading:



Inverter shutdown operation parameter table (1000H)

Parameter Address	Parameter Description	Parameter Address	Parameter Description
1000H	Communication setpoint	1010H	PID settings
1001H	Operating frequency	1011H	PID feedback
1002H	Bus voltage	1012H	PLC steps
1003H	Output Voltage	1013H	PULSE Input pulse frequency in 0.01kHz
1004H	Output Current	1014H	Feedback speed, unit 0.1Hz
1005H	Output power	1015H	Remaining running time
1006H	Output torque	1016H	AI1 voltage before correction
1007H	Running speed	1017H	AI2 voltage before correction
1008H	DI input flag	1019H	Line Speed
1009H	DO output flag	101AH	Current power-up time
100AH	AI1 voltage	101BH	Current running time
100BH	AI2 voltage	101CH	PULSE input pulse frequency in 1Hz
100CH	Reserved	101DH	Communication setpoint
100DH	Counting value input	101EH	Actual feedback speed
100EH	Length value input	101FH	Main frequency X display
100FH	Load speed	1020H	Auxiliary frequency Y display

**Note:** The communication setting value 1000H parameter value, corresponding to is the percentage of the relative value of the maximum frequency, 10000 corresponds to 100.00%.

#### 4.2) Inverter fault reading 8000H.

When the communication reads the inverter fault description, the communication address is fixed to 8000H.

8000H	0000: No fault	0012: Current detection fault
	0002: Accelerated overcurrent	0013: Motor tuning failure
	0003: Deceleration overcurrent	0015: Parameter read/write exception
	0004: Constant speed overcurrent	0016: Inverter hardware failure
	0005: Accelerated overvoltage	0017: Motor short circuit to ground fault
	0006: Deceleration overvoltage	001A: Runtime arrival
	0007: Constant velocity overvoltage	001D: Power-up time arrival
	0008: Buffer resistor overload fault	001E: Dropped load
	0009: Undervoltage fault	001F: Loss of PID feedback at runtime
	000A: Inverter overload	0028: Fast current limit timeout fault
	000B: Motor overload	0029: Switching motor failure during operation
	000C: Input out of phase	002A: Excessive speed deviation
	000D: Output out of phase	002D: Motor overtemperature
	000E: Module overheating	0047: High Voltage Alarm
	000F: External fault	0048: Low pressure alarm
	0010: Communication anomaly	0049: Water shortage failure
	0011: Contactor abnormalities	004A: Burst pipe alarm

#### 4.3) Inverter operation status reading 3000H.

When the communication reads the inverter operation status, the communication address is fixed to 3000H, and the upper computer can obtain the current inverter operation status information by reading the address data, which is defined as follows.

Inverter operation status address	Read status word definitions
3000H	1: Positive rotation operation
	2: Reverse operation
	3: Shutdown

**4.4) Control parameter control command 2000H.**

The control parameters are control commands, through which the operation of the inverter is controlled.

When F0-02 (command source) is selected as 2: communication control, the upper computer can realize the start/stop and other related command control of the inverter through this communication address, and the control command is defined as follows.

Control command communication address	Command Functions
2000H	1: Positive rotation operation
	2: Reverse operation
	3: Positive rotation point movement
	4: Reversal of point movement
	5: Free stop
	6: Deceleration stop
	7: Fault reset

**(4.5) U0 parameter status monitoring array data reading (7000H).**

Reads the inverter value defined by the U0 parameter group at the space starting at 0x7000H, as described below.

U0 to UF, whose communication address is 70 to 7F in the high sixteen bits and the serial number of the monitored parameter in the group in the low sixteen bits.

An example is U0-11, whose communication address is 700BH.

# Warranty Agreement

- 1、 The product warranty period is eighteen months (subject to the body bar code information), the warranty period in accordance with the instructions for normal use, the product failure or damage, our company is responsible for free maintenance.
- 2、 During the warranty period, a repair fee will be charged for damage caused by
  - A. Damage to the machine caused by errors in use and unauthorized repair or modification by oneself.
  - B. Machine damage due to fire, flood, voltage abnormalities, other acts of God and secondary disasters.
  - C. Hardware damage due to man-made drops and transportation after purchase.
  - D. Machine damage caused by not operating according to the user manual provided by our company.
  - E. Failure and damage caused by obstacles other than the machine (such as external equipment factors).
- 3、 In case of product failure or damage, please fill out the contents of the Product Warranty Card correctly and in detail.
- 4、 Maintenance fees are charged in accordance with our newly adjusted "Maintenance Price List".
- 5、 This warranty card will not be reissued under normal circumstances, so please make sure you keep this card and present it to the service personnel at the time of warranty.
- 6、 If you have any questions during the service, please contact our agent or our company in time.
- 7、 The right to interpret this agreement belongs to our company.

# Product Warranty Card

Customer Information	Unit address.	
	Unit Name.	Contact person.
		Contact number.
Product Information	Product Model.	
	Body barcode (pasted here).	
	Agent Name.	
Fault Information	(Time and content of repair).	
	Maintained by.	



**THANK YOU !**  
For Using Our CT10M Series Products

**BENCERA RESOURCES LLP.**

Add: 710, Iscon Elegance

opp Karnavati Club, Next to Shapath-V

S.G ROAD, Ahmedabad-380015

Tel: + 91 95120 09895 / +91 97226 09663

Email: sales\_thyra@gmail.com

**THYRA**